

Workers' Tool or PR ploy?

A guide to codes of international labour practice

by

Ingeborg Wick

2003, 3rd revised edition

Friedrich-Ebert-Stiftung
Department for Development Policy
- Dialogue on Globalization -
Hiroshimastr. 17
10785 Berlin
Tel.: 0049-30-26936-914
Fax: 0049-30-26935-959
Roswitha.Kiewitt@fes.de
www.fes.de/globalization

*The opinions expressed in this paper do not necessarily reflect the views
of the Friedrich-Ebert- Stiftung or the organisations for which the author works.*

Workers' tool or PR ploy?

3rd revised edition

**A guide to codes
of international
labour practice**

By Ingeborg Wick



**FRIEDRICH
EBERT
STIFTUNG**



Workers' tool or PR ploy?

A guide to codes of international labour practice

BY INGEORG WICK

Friedrich-Ebert-Stiftung / Bonn, Germany

SÜDWIND Institut für Ökonomie und Ökumene / Siegburg, Germany

2003

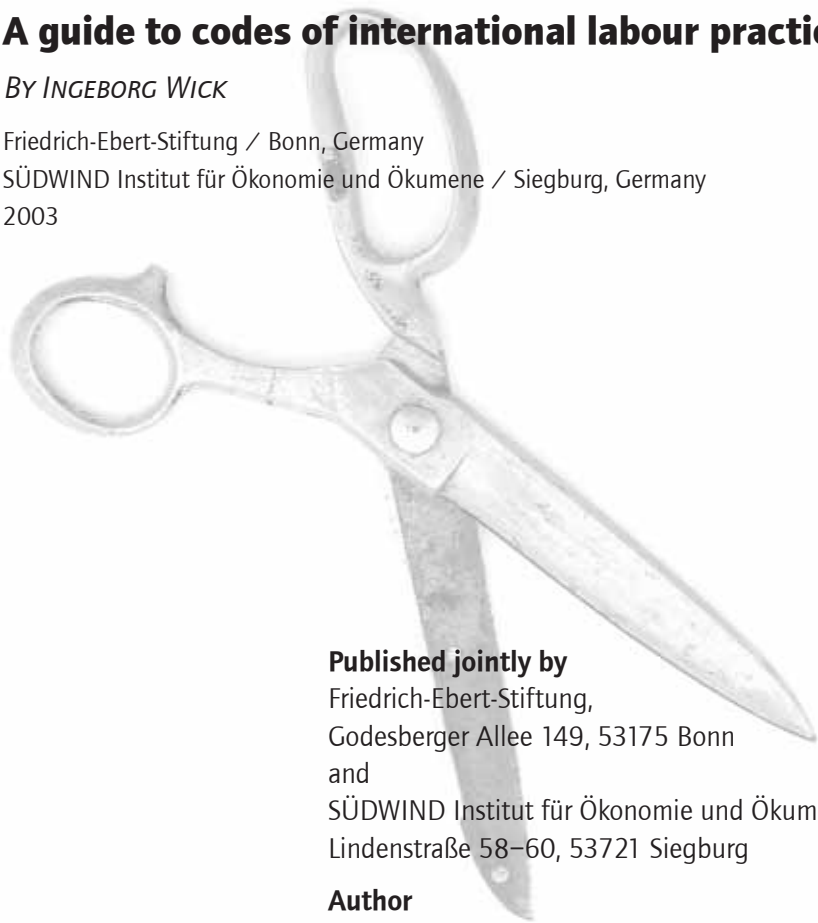

Published jointly by

Friedrich-Ebert-Stiftung,

Godesberger Allee 149, 53175 Bonn

and

SÜDWIND Institut für Ökonomie und Ökumene,

Lindenstraße 58–60, 53721 Siegburg

Author

Ingeborg Wick

Cover design and layout:

Frank Zander

Printed by

Toennes Satz + Druck, Erkrath

Bonn/Siegburg 2003

ISBN 3-86077-979-6

3rd revised edition

Table of contents

	PREFACE	4
1.	INTRODUCTION	5
2.	RESTRUCTURING OF THE WORLD ECONOMY	9
3.	BASIC INFORMATION ON TRADE-RELATED INITIATIVES	14
3.1	Ethical consumption	14
3.2	WTO: the social clause	16
3.3	Framework agreements	18
3.4	Codes of conduct	20
4.	PROFILES OF CODES OF CONDUCT IN THE APPAREL AND SPORTSSHOE SECTOR	27
4.1	Clean Clothes Campaign	27
4.2	Social Accountability International	36
4.3	Ethical Trading Initiative	43
4.4	Fair Labor Association	50
4.5	Worker Rights Consortium	56
4.6	Further code of conduct initiatives	62
4.7	Overview and comparison	68
5.	PERSPECTIVES	88
6.	"THE NEW CODES OF CONDUCT – SOME QUESTIONS AND ANSWERS FOR TRADE UNIONS" ..	92
	by Neil Kearney/ITGLWF and Dwight Justice/ICFTU	
7.	APPENDIX	115

Preface to the 3rd revised edition

The international debate on codes of conduct has gained further momentum since the first publication of "Workers' tool or PR ploy?" in March 2001. This debate reflects a growing worldwide movement questioning the social impact of globalisation.

At the beginning of 2002, the International Labour Organisation launched a World Commission on the Social Dimension of Globalisation. In July 2002, the European Commission adopted a White Paper on Corporate Social Responsibility which highlighted the voluntary nature of corporate activities to improve labour conditions in global supply chains. However, in May 2002, the European Parliament, in a second initiative on codes of conduct, had voted in favour of a new legislation to require companies to publicly report annually on their social and environmental performance. More and more business and governments promote the concept of voluntary "Corporate Social Responsibility" as an alternative to binding labour legislation. But since the beginning of the 90s, the international community has been calling for codes of conduct and independent multi-stakeholder verification bodies as a supplement, and not an alternative, to government regulation.

The five prominent code of conduct models analysed in this publication are all independent multi-stakeholder initiatives. During the past months, they have shown some converging tendencies, despite their varied differences. This common ground should continue to be explored in the future, so that the obvious potentials of codes of conduct can be strengthened to improve of human and labour conditions in world trade.

The first and second editions of this booklet have been translated into several languages and are used for worker education programmes in different countries. May the third revised edition and further envisaged translations also serve this purpose, and contribute to turn codes of conduct into useful tools in the hands of workers.

FRIEDRICH EBERT STIFTUNG

SÜDWIND-INSTITUT FÜR ÖKONOMIE UND ÖKUMENE

1. Introduction

During the past 30 years, a new social movement has emerged in many countries to concern itself with the improvement of world-wide labour conditions in addition to the trade union movement.

This development has unfolded against the background of the radical restructuring of the world economy since the 1970s. This restructuring has been accompanied by intensified social degradation – especially in the third world, but also in industrialised countries – as well as increasing environmental destruction and discrimination against women. These processes are often intertwined. New forms of resistance developed: the ecological and women's movements gained momentum and new social alliances were formed. In 1992 for instance, when the UN Conference on Environment and Development took place in Rio de Janeiro, a broad network of environmental and third-world organisations, unions, other labour-related organisations and women's groups conducted parallel conferences and lobbying activities to voice their concerns. Since then, networking has increasingly taken place between new and tradi-

EXPORT-PROCESSING ZONE IN SAN SALVADOR



(M. ROSERY/CIR)

tional formations in societies around the world – not only during UN world conferences in the 90s, but also in connection with leading financial and economic institutions like the World Bank, the International Monetary Fund (IMF), the World Trade Organisation (WTO) and the Organisation for Economic Cooperation and Development (OECD). Since 2001, the high-ranking conferences of the World Economic Forum have been accompanied by World Social Forums in Porto Alegre with tens of thousands of participants from around the world challenging the impact of neoliberal globalisation. The international ATTAC movement which demands a democratic control of financial markets and their institutions, is spreading worldwide.

Ethical production and consumption is the aim of several trade-related initiatives launched in recent years, including alternative trade, social labeling, WTO campaigns, framework agreements and codes of conduct. These initiatives are formidable challenges to the traditional workers' movement.

This brochure deals with the potential of new social alliances in the field of trade-related initiatives focusing on codes of conduct.

In the early 1970s, **alternative trade** organisations established direct trade links with third-world producers and offered them better conditions than those obtainable from ordinary trading companies. Consumers in northern countries began to apply ethical criteria to their shopping, choosing third-world products to help improve the working and living conditions of those who produced these goods. Ethical consumption in support of ethical production and trade was embraced by a broad movement of third-world solidarity, church, consumers and women's groups, which centred their activities around thousands of "one-world shops" in the Netherlands, Switzerland, Germany, Sweden and elsewhere. Although the overall market share of ethically traded goods remains rather small, the one-world-shop movement in the North with its links to southern partners has become a stable political factor in many societies of the world today.

Arising from this movement, **social label** organisations and products gradually penetrated traditional commerce. More and more third-world products with independent labels (coffee, tea, cocoa, honey, sugar, bananas, orange juice, carpets, flowers, etc.) are now being sold to industrial world consumers in supermarkets, schools and company canteens. While their market share admittedly



GARMENT FACTORY IN MAURITIUS

remains modest in most cases, it is nevertheless no longer possible to ignore the political role of the fair trade movement in questioning the current world trade system.

In the 1980s, world-wide criticism of the GATT (General Agreement on Tariffs and Trade) regime increased in the light of the growing impoverishment of indebted developing countries. When the **WTO** took over as the GATT successor organisation in 1995, its intensified liberalisation policy and disregard of social disparities in world trade provoked wider protests. International networks of non-governmental organisations (NGOs) and unions were formed. They successfully opposed the opening of the WTO millennium round in Seattle, USA in December 1999. Previously, the 1995 UN Social Summit in Copenhagen had already proved that opposition to the WTO trade regime was shared not only by NGOs, unions and international organisations, but also by a number of governments.

Since 1996, the issue of whether to introduce a social clause into the framework of the WTO has been the subject of a controversial international debate. So far, the controversy has deviated from the usual pattern of debates about

development questions because its dividing lines cut right across Southern and Northern regional boundaries, governments, unions and NGOs.

The intensifying internationalisation of production and the growing social marginalisation of millions of people during the past two decades (especially in the third world, but also in industrialised countries) caused unions and their international umbrella organisations to start developing a series of **framework agreements**. These agreements between Global Union Federations (formerly International Trade Secretarits) and transnational corporations (TNCs) are a direct union response to the new demands of an economy undergoing globalisation.

Codes of conduct for TNCs which have been proliferating since the early 1990s, represent another new kind of challenge to the international labour movement. Their roots go back to the conventions of the ILO, the OECD "Guidelines for Multinational Enterprises" of 1976, the ILO "Tripartite Declaration of Principles concerning Multinational Enterprises and Social Policy" of 1977 and a number of similar codes in the 1970s, all of which lacked enforcement mechanisms and too often failed to produce positive results in practice. But these failings are not the only reason for the avalanche of codes of conduct produced since the early 1990s. They are also a response to more recent developments and require new explanations.

Codes of conduct are the main subject of this brochure, both because they are increasingly favoured by TNCs and governments and because considerable confusion exists among workers and NGOs about the pros and cons of this instrument. In order to exploit the opportunities offered by codes of conduct, it is necessary to know their background, role, limitations, advantages and main features, as well as to study a number of examples.

A comparison of current prominent code models is therefore at the heart of this brochure (chapter 4) as well as an analysis of the International Confederation of Free Trade Unions (ICFTU) and the International Textile, Garment & Leather Workers' Federation (ITGLWF) entitled, "The new codes of conduct. Some questions and answers for trade unions" (chapter 6).

Before going into the details of codes of conduct, the brochure will offer a closer look at the socio-economic context in which they operate and provide some basic information on the above-mentioned trade-related initiatives.

2. Restructuring of the world economy

Since the 1970s, the Fordistic economic model followed by Western economic policies since the end of World War I has slowly been phased out and replaced by neoliberalism. Fordism was marked by steady economic growth, high profit rates, steady wage increases, low unemployment and increasing consumer spending power. With the rise of neoliberalism, however, the influ-



WATCH-TOWER IN THE
EXPORT-PROCESSING
ZONE KBN/JAKARTA,
INDONESIA

(i. Wick)

ence of private capital was strengthened by the policy of liberalisation and deregulation.

Since 1972, the liberalisation of the financial markets has produced literally spectacular results, exerting an increasing pressure on all other economic activities in the world.

The UNCTAD „World Investment Report 2002“ highlights an increased influence of transnational corporations (TNCs) during the past years, revealing that in 2001 the sales of about 850,000 foreign affiliates of about 65,000 TNCs reached US \$ 19 trillion (as compared to US \$ 9.5 trillion in 1990) – the equivalent of one-tenth of world Gross Domestic Product and one-third of world exports. (1) This UNCTAD report states: „The growth of international production systems reflects the response of TNCs to dramatic changes in the global economic environment: technological change, policy liberalization and increased competition. Falling barriers to international transactions allow TNCs to locate different parts of their production processes, including various service functions, across the globe, to take advantage of fine differences in costs, resources, logistics and markets. (...) Global markets therefore increasingly involve competition between entire production systems, orchestrated by TNCs, rather than between individual factories or firms.“ (2)

About two thirds of world foreign direct investments (FDI) take place in the industrialised countries. Whereas the share of FDI in developing countries increased from 17% in 1981–90, to 32% in 1990–2000, the bulk of these investments were concentrated in a few countries like China, Mexico, and South Africa. In 2001, FDI flows to the least developed countries only made up 2% of world FDI.

Developing countries do not only suffer from the marked asymmetry of international FDI flows. In cases of increasing investments they also do not necessarily profit from more

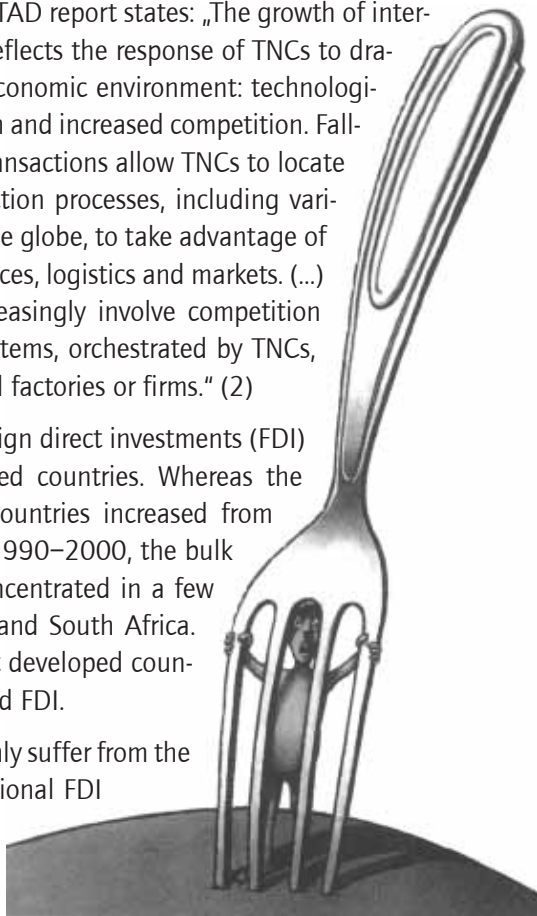

(F. ZANDER)



STREET VENDOR IN BIRCHENOUGH BRIDGE/ZIMBABWE

value added. The activities of TNCs are seldom rooted in host countries.

Flexible employment practices were introduced into labour markets, thereby reducing social security protection for the majority of the workers. Informalisation of labour is a by-product of the reorganisation of corporate business policies towards relocating production to cheaper areas of the world. In the 90s, about 90% of all new jobs in Africa were created in the informal sector. (3)

When the debt crisis started in the early 1980s, the World Bank and the IMF imposed „Structural Adjustment Programmes“ (SAPs) on developing countries, requiring them to reduce government expenditures on employment and social programmes and open their markets to foreign investment. This led to increased labour and human rights violations and more widespread ecological devastation. International relocations and world-wide sourcing enabled TNCs to evade national labour regulations and profit from international competition between low-cost production sites. Therefore, as the influence of TNCs on the economic and social development of individual countries and the international community grew, social standards steadily declined.

Labour-intensive production has increasingly been shifted into "Export-Processing Zones" (EPZs) and the informal sector in the third world. Next to electronics, the textile and garment/sportshoe industries are the dominant sectors in the more than 2 000 EPZs of about 70 developing and newly industrialised countries, employing an estimated 70 to 100 million workers – including the Chinese special economic zones. (3) Many of these EPZs are exempt from national labour legislation. Further characteristics are the prohibition or obstruction of union activities and the predominance of female workers. Sixty to seventy percent of the workers are women between the ages of 18 to 25. (4)

This pattern of female employment in EPZs and in the informal sector is no coincidence. Companies gain several advantages by employing women. First, their wages are lower than for men (which also applies in highly industrialised countries). Secondly, young women who are often from rural areas and highly motivated to earn their living for the first time, have no opportunities to compare their working conditions with those of others. And thirdly, the double burden of unpaid family work and paid labour allows women hardly any op-

GARMENT FACTORY IN KENIA



(CCC-NL)

portunity to organise themselves in unions. And even if they were organised, they would still face the problem that many women's jobs are poorly paid or form part of the socially unprotected, informal sector in the very same labour-intensive industries where trade unions all over the world have lost ground for their organising activities during the past few decades.

ENDNOTES

(1) UNCTAD "World Investment Report 2002, p. XV"

(2) *op.cit.*, p. XXI

(3) ILO "Decent work and the informal economy", Report VI, International Labour Conference, 90th Session, June 2002 Geneva, p. 20

(4) *Revista de la Cepal* 67, Abril 1999 / ILO press release 28 September 1998 / Wick, Ingeborg "Frauenarbeit in Freien Exportzonen", in: *Globalisierung und Peripherie*, HSK 14, Wien 1999, p. 191

(5) Wick, Ingeborg "Frauenarbeit ...", p. 191/192

3. Basic data on trade-related initiatives

3.1 Ethical consumption

In recent years, consumers in industrialised countries have shown considerably increased concern for the social and environmental conditions under which the goods they buy were produced.

The UNDP "Human Development Report" 1999 stated:

"In the space of a few years, the fair trade movement and the promotion of fairly traded goods have gone from the margin to the mainstream in promoting labour rights, and retail sales of fairly traded goods are worth more than US \$ 250 million in Europe alone. This could be replicated at the global level in many ways." (1)



To date, however, the overall (i.e. worldwide – author's note) market share of social-label products is about 1–4% or less, with few exceptions like the 15% share of fairly traded bananas on the highly monopolised Swiss food market. (2)

Recent case studies on the results of fair trade for the small producers in South East Asia, East Africa and Central America have shown that, notwithstanding some deficits and failures, fair trade has generally contributed to improving income and social benefits. (3)

There are four international umbrella organisations of fair trade: a) the "Fair Trade Labeling Organisations International" (FLO), b) the "International Federation for Alternative Trade" (IFAT), c) the "Network of European World Shops" (NEWS) and d) the European Fair Trade Association" (EFTA). Their informal joint working committee "FINE" defines fair trade as a "trade partnership which aims at a sustainable development for excluded and underprivileged producers by granting better trade conditions, by conscientisation work and campaigns." (4)

The number of member organisations of these four organisations and of countries covered by them is as follows: a) FLO – 17 member organisations in 17 countries, b) IFAT – 148 member organisations in 48 countries, c) NEWS – 15 member organisations in 13 countries, and d) EFTA 12 member organisations in 9 countries. (7)

An overall assessment of a fair trade study dated 2000 stated that the con-

ETHICAL SHOPPING CRITERIA OF GERMAN HOUSEHOLDS

Reasons for Preference of certain companies ¹	
Those households, who prefer companies that show social responsibility (even occasionally), do so because:	
→ of the avoidance of child labour:	53 %
→ the products they bought were environmentally friendly:	39 %
→ energy and inputs were saved:	39 %
→ the company does not deal with countries with grave human rights violations:	37 %
→ the company is not in any way linked to the arm's industry:	32 %
→ the company shows commitment in developing countries:	28 %
→ the company integrated immigrants in their workforce:	19 %

¹ The data was gathered in market research carried out by the Institut für Market - Environment - Society (IMUG) / Hannover in December 1999

(SOURCE: PIEPEL 2000)

centration on small producers in developing countries is questionable, since industrial production is much more important for many of these societies and should be included into the system of preferential treatment. (6)

ENDNOTES

- (1) UNDP "Human Development Report 1999", p. 101
- (2) Krier, Jean-Marie. "Fair Trade in Europe 2001. Facts and Figures on the Fair Trade sector in 18 European countries", publ. by EFTA, Brussels 2001, and Piepel, Klaus "Social labels and codes of conduct", publ. by Misereor/Brot für die Welt, Fair Trade Policy No. 2, Aachen 2000
- (3) Misereor/Brot für die Welt/Friedrich-Ebert-Stiftung (Hg.) "Entwicklungspolitische Wirkungen des Fairen Handels", Aachen 2000, p. 185–269
- (4) Kleinert, Uwe "Inlandswirkungen des Fairen Handels", in: Entwicklungspolitische Wirkungen des Fairen Handels, Aachen 2000, p. 31
- (5) Piepel, Klaus *op.cit.*, p. 7
- (6) Misereor/Brot für die Welt/Friedrich-Ebert-Stiftung: *op.cit.*, p. 296

3.2 WTO and the Social Clause

The IMF, the World Bank and the WTO are the most important pillars of the system of multilateral governance in the world economy. The 144 member countries of the WTO seek further liberalisation of world trade. But the mandate of the WTO extends far beyond the trading of goods. The WTO also covers related areas such as services, investment, intellectual property rights, competition, legislation etc.. World trade is increasingly integrating the markets for goods, capital and labour. Decisions of the WTO directly or indirectly affect central aspects of the economic, structural, labour, and social policies of national governments. Despite its far-reaching national and international influence, however, the WTO is not subjected to any effective democratic control.



GARMENT FACTORY NEAR JAKARTA/INDONESIA

National parliaments, unions and NGOs have only a very limited influence on the WTO.

There is wide-spread opposition to the introduction of a social clause into the framework of the WTO, especially from governments and NGOs in the so-called "transition" countries in the South as well as from some Northern NGOs. They do not primarily reject the basic idea of a social clause as such. Instead, their main argument is that the trade sanctions which would inevitably follow non-compliance with the social clause would further hamper the export chances of developing countries and constitute another protectionist tool in the hands of industrialised countries. From a different perspective, business in the North also opposes a social clause: the main reason given is that it would represent a regulatory measure and obstruct the liberalisation and deregulation of world trade.

On the other hand, governments of industrialised countries and the International Confederation of Free Trade Unions (ICFTU) support the proposed social clause. In doing so, the ICFTU is motivated by the inadequacy of the existing mechanism to implement ILO labour standards and by the world-wide social degradation which has accompanied the rise of neoliberalism. It cannot be de-

nied that the supportive stance of the Northern governments is partly inspired by protectionist interests, since a series of other WTO decisions has shown a lack of serious consideration by these governments for the interests of most third-world inhabitants. Why for instance do Northern governments fail to oppose the establishment of "Export-Processing Zones" in developing countries, where many of the national labour laws are officially ruled inapplicable? And why do the hundreds of existing "Bilateral Investment Treaties" between industrialised and developing countries make no provisions for labour standards?

Any serious effort to insert a social clause into the framework of the WTO must therefore be linked to simultaneous processes involving the abolition of contradictory, anti-social decisions by the WTO and a democratic transformation of the WTO.

3.3 Framework agreements

"A framework agreement is an agreement negotiated between a multinational company and an international trade union organisation such as a Global Union Federation GUF, formerly Internatinal Trade Secretariat) concerning the international activities of the company. Although an international code of conduct can be part of a framework agreement, the main purpose of a framework agreement is to establish an ongoing relationship between the multinational company and the international trade union organisation."

(see chapter 6, p. 76)

"Because the GUF have affiliates throughout all regions of the world and often in both home and host countries, they are the legitimate international voice of workers in their respective industries or economic sectors. An additional advantage of working through an GUF is that trad eunions will be addressing specific situations while, at the same time, strengthening the international trade union movement." (chapter 6, p. 76/77)

In recent years the following framework agreements on labour standards have been concluded between GUF and TNCs:

* Agreement includes explicit health and safety clauses.

Company	Country	Branch	GUF	Year
Danone	Switzerland	Food Processing	IUF	1988
Accor	France	Hotels	IUF	1995
IKEA *	Sweden	Furniture	IFBWW	1998
Statoil *	Norway	Oil Industry	ICEM	1998
Faber-Castell *	Germany	Office Material	IFBWW	1999
Freudenberg *	Germany	Chemical Industry	ICEM	2000
Hochtief	Germany	Construction	IFBWW	2000
Carrefour	France	Commerce	UNI	2001
Chiquita *	USA	Agriculture	IUF	2001
OTE Telecom *	Greece	Telecommunication	UNI	2001
Skanska *	Sweden	Construction	IFBWW	2001
Telefonica *	Spain	Telecommunication	UNI	2001
Merloni	Italy	Metal Industry	IMF	2002
Endesa *	Spain	Power Industry	ICEM	2002
Ballast Nedam	Netherlands	Construction	IFBWW	2002
Fonterra *	New Zealand	Dairy Industry	IUF	2002
Volkswagen *	Germany	Auto Industry	IMF	2002
Norske Skog *	Norway	Paper	ICEM	2002
AngloGold *	South Africa	Mining	ICEM	2002
DaimlerChrysler*	Germany	Auto Industry	IMF	2002



Wherever an assessment can already be made these framework agreements turned out to be useful instruments – irrespective of a number of deficits and obstacles. For instance the relationship between the management and the workers' representatives of Nestle in Europe improved considerably after the framework agreement had been concluded in 1996. As a result of the framework agreement between the Accor hotel group and the IUF the management of the company's hotels in the USA and Australia noticeably reduced their anti-union stand. The framework agreement between Del Monte and the IUF of 2000 led to banana workers in Guatemala getting back their jobs and being compensated for wage losses.

It is clear that the framework agreements could only be concluded because of strong pressure from the unions accompanied by media activities. And these agreements undoubtedly will have to be followed up by a continuous process in which unions will have to show their power both locally and internationally.

In some industries, however, the presence of unions is greatly diminished or has never been strong, due partly to the restructuring of the world economy in recent years and partly historical deficiencies of the unions themselves, such as gender-biased organising practices. This applies to textile and garment industries all over the world, for instance. It is no coincidence, therefore, that most of the codes of conduct developed in the recent past originated in this sector.

3.4 Codes of conduct

THE PROLIFERATION OF CODES OF CONDUCT

Codes of conduct are booming. In view of this proliferation and public debates dating back to the early 1990s, the UN, the "Organisation for Economic Cooperation and Development" (OECD), the European Commission, the European Parliament, the ILO and the ICFTU have recently produced analyses, initiatives, codes or redrafts of codes. For instance, the UN "Global Compact" initiated by UN Secretary General Kofi Annan in 1999, the revised version of the "OECD Guidelines for Multinational Enterprises" dated June 2000, the ILO "Overview

of global developments and Office activities concerning codes of conduct, social labelling and other private sector initiatives addressing labour issues" of November 1998 and the ICFTU Basic Code of Labour Practice of 1997 must be seen in this context.

A brief look at the total number of existing codes of conduct shows that the largest share relates to the textile and garment sector. This industry is highly internationalised and labour-intensive, is located mainly in third world and Eastern European countries and operates a sophisticated sub-contracting system. During the past 30 years, the labour conditions of the majority of workers along the supply chain have deteriorated – through an increase of informal work in sweat shops and at home, through child labour and through an extension of "Export Processing Zones" to many parts of the world. The ILO study on "Labour practices in the footwear, leather, textiles and clothing industries", published in October 2000, states that child labour, forced labour and discrimination against women are typical features of employment in this sector of industry.

Before proceeding to describe and analyse some prominent models of codes of conduct in the garment and sportsshoe sector, it will be necessary to provide a definition of codes of conduct, some basic information and a brief outline of their historical context.

COMPOSITION OF CODES BY TYPE OF ISSUER

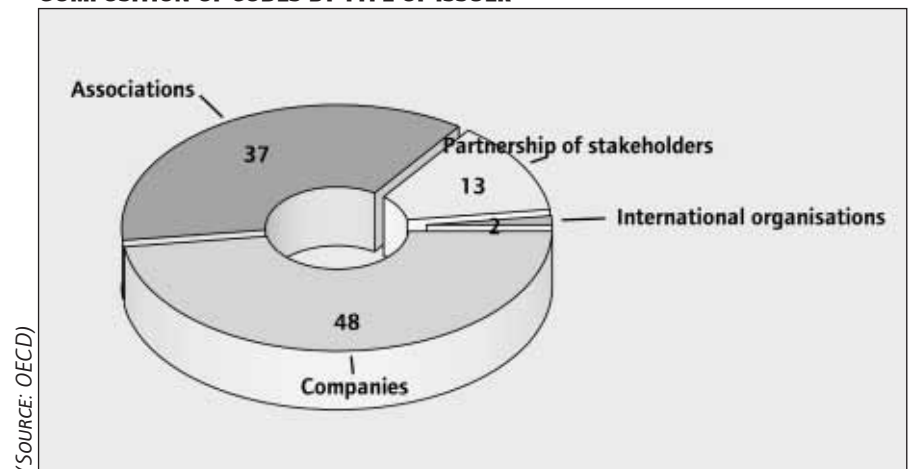

DEFINITION AND BASIC INFORMATION

In a review dated June 2000 (1), the OECD lists 246 codes of conduct, most of which were issued in the 1990s.

They are broadly defined as “commitments voluntarily made by companies, associations or other entities which put forth standards and principles for the conduct of business activities in the marketplace”.

Of the 246 codes of conduct, 118 were issued by individual companies, 92 by industry and trade associations, 32 by partnerships between stakeholders including unions and non-governmental organisations (NGOs) and 4 by inter-governmental organisations.

Of the 246 codes of conduct, 37 relate to the textile and clothing industry.

ISSUE AREAS ADDRESSED BY THE CODES

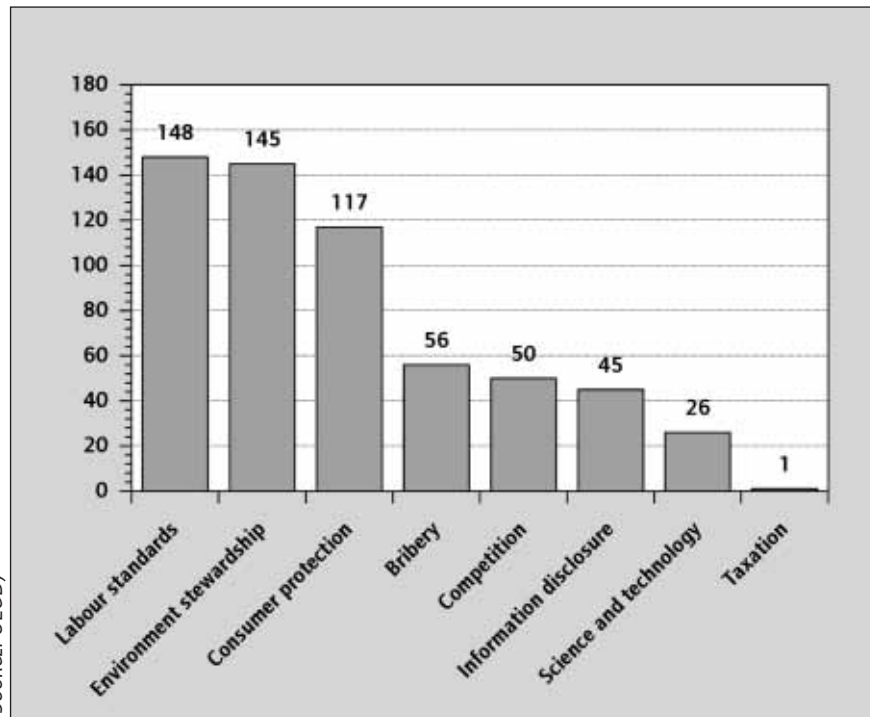

(SOURCE: OECD)

Five of these were produced by coalitions of entities and 32 by individual companies – 25 of them from the USA. While 36 of the 37 codes related to the textile and clothing industry prohibit the use of child labour, fewer than 50% of them mention freedom of association. Of the company codes, 26 are addressed to suppliers and contractors and 23 do not mention monitoring systems.

Only 163 of the overall 246 codes of conduct mention monitoring. Internal monitoring is explicitly permitted by 137 codes, while 26 approve external monitoring only.

Of the 246 existing codes, 67 originated in the USA, 23 in the United Kingdom, 20 in Australia, 17 in Canada, 11 in Germany and 10 in Switzerland.

COUNTRIES OF ORIGIN BY ISSUER OF CODE

	NUMBER OF CODES
Australia	20
Austria	4
Belgium	2
Canada	17
Czech Republic	4
Denmark	2
Finland	4
France	9
Germany	11
Greece	2
Italy	5
Japan	8
Korea	7
Luxembourg	1
Mexico	3
Netherlands	2
New Zealand	4
Norway	3
Spain	4
Sweden	6
Switzerland	10
United Kingdom	23
United States	67
Two or more countries	9
International	19

(SOURCE: OECD)

A HISTORICAL SUMMARY

The first codification of world-wide labour rights was achieved in 1919, when the newly founded “International Labour Organisation” adopted the first internationally binding convention. The ILO is composed of governments, unions and employers. By now, the ILO has adopted 184 conventions for the protection of workers’ rights. Due to their lack of sanctions, however, the ILO Conventions have too often remained ineffective in practice. Similar deficiencies have hampered attempts by the OECD, UNCTAD and the UN Commission on



HOMEWORKERS IN SOUTH AFRICA

Transnational Corporations to make transnational companies (TNCs) liable for their social obligations in terms of international law. This problem is made all the more serious by the fact that, since the late 1970s, TNCs have increasingly evaded their social responsibilities and asserted more extensive rights as investors.

Since the early 1990s, the growing vacuum in applied labour legislation and the difficulties facing the union movement's attempts to grapple with the effects of neoliberal globalisation have caused labour-related NGOs to cooperate with unions in mobilising public opinion in industrialised countries against the socially and ecologically devastating policy of the TNCs. Electronic communications have helped to produce speedy headline reports in western media about labour and environmental rights violations, especially in the plants of TNC suppliers in developing countries. Global competition is so intense that any damage to the image of a TNC can easily turn into economic losses. To a certain extent, this explains the readiness of TNCs to talk to citizens' groups which use codes of conduct as a political instrument.

In the light of these dynamics, the definition of a conduct code as a "voluntary"

commitment by a company seems questionable. In political, if not in purely legal terms, there is also an element of pressure behind this commitment.

CODES OF CONDUCT IN THE GARMENT/ SPORTSSHOE INDUSTRY

In the early 1990s, the Dutch "Clean Clothes Campaign" (CCC) and the predecessors of the "Anti-Sweatshop Movement" in the USA informed the public about inhumane labour practices in plants of third-world suppliers to C&A and Levi's. These companies initially tried to deflate public pressure by talking to the protest groups and adopting internal conduct codes without making material concessions. Other NGOs and unions in other countries have had similar experiences with other companies. In many cases, the companies involved denied labour rights violations, criticised the information policy of the NGOs and threatened to take legal action. Some companies have also terminated business relations with suppliers in the third world, thereby increasing the social misery of the workers by causing them to lose their jobs. While keeping up their public pressure on TNCs, NGOs and unions therefore targeted international sourcing practices which expose most of the workers to social degradation. Once public opinion started producing economic effects – in the USA, for instance, many universities threatened to cancel licensee agreements with Nike or Reebok unless they agreed to sign codes of conduct – some companies gradually made more significant concessions. For instance, freedom of association was added to the catalogue of social standards set by codes of conduct. In another example of company concessions, the first steps have been taken towards independent verification of conduct codes.

CODES OF CONDUCT ARE NO SUBSTITUTE FOR GOVERNMENTAL REGULATION

If conduct codes are treated as an alternative to governmental regulation rather than a complementary instrument, they pose the risk of promoting the privatisation of the labour and social policies imposed by neoliberalism during

the past 20 years. Unions and NGOs would grossly overestimate their capacities if they sought to achieve the verification of labour conditions at the global production sites of all suppliers to TNCs. Nike for instance obtains its products from thousands of direct and indirect suppliers. Now that trade union bargaining power has been curtailed by the deregulation policy of governments and the subsequent "race to the bottom" of global social conditions, many expectations are being pinned to NGOs as a potential force to limit the influence of TNCs. However, the role of the NGOs should not be overestimated and the danger of their being misused must be seen quite clearly. Against the background of the previously described vacuum in regulated labour relations, they can hardly function as more than catalysts to encourage the (better) enforcement of existing laws or the creation of new legislation – either nationally or internationally.

CODES OF CONDUCT REQUIRE NEW SOCIAL ALLIANCES

However, this catalyst function is extraordinarily challenging. It requires new social alliances: between the trade union movement and women's organisations, for instance. In labour-intensive global industries like the textile and garment industry, in the EPZs and in the informal sector, the predominance of women workers is obvious. While social conflicts have certainly intensified during the past few decades, codes of conduct can nevertheless be used as platforms to develop of a new type of labour organisation.

ENDNOTES

(1) OECD "Codes of Corporate Conduct – An Expanded Review of their Contents", 7 June 2000

4. Profiles of codes of conduct in the apparel and sportswear sector

The apparel and sportsshoe sector is the source of the greatest share of the conduct codes issued since the early 1990s.

Five currently prominent models of codes in the garment/sportswear industry will be introduced and analysed below, starting with the code of the Clean Clothes Campaign as the one with the longest history.

It should be borne in mind that these code models are still rather new and are thus undergoing experimental processes. Therefore, not all of them provide definite answers to the topics discussed here.

4.1 Clean Clothes Campaign (CCC)

GENERAL INFORMATION

Founded in 1990 in the Netherlands, the CCC exists in 12 European countries today. The work of the autonomous national platforms is coordinated by an international secretariat in Amsterdam.

The European CCC is a network of over 250 unions and NGOs's (consumer organisations, solidarity and church institutions, women's organisations etc.).



The CCC aims to improve labour conditions in the worldwide garment and sportswear industry by informing consumers, influencing companies and supporting workers' organisations.

In cases of labour strikes, retrenchments or compensation claims of garment/sportsshoe workers, for instance, the CCC intervenes with press releases and protest letters or by collecting donations, etc.

The “Code of Labour Practices for the Apparel Industry including Sportswear” was adopted in February 1998 after close consultation with world-wide partners and international union organisations (CCC Code). The more than 250 signatories include the International Textile, Garment & Leather Workers' Federation (ITGLWF), the European Trade Union Federation for Textile, Clothing and Leather (ETUC/TCL), the Asia Monitor Resource Center (AMRC), the Transnational Information Exchange Asia (TIE Asia) etc.

Legal initiatives and moves to secure government involvement have been gaining momentum over the past few years: for instance, the Dutch Parliament is discussing a bill on consumer rights to inform about labour conditions of garment and sportshoe workers. A bill providing for the extraterritorial extension of Belgian labour laws to the foreign operations of local companies was tabled in the Belgian parliament in 1999, and is still pending. The chairperson of the Dutch Fair Wear “Foundation” in which the CCC is a member, is a former minister in the Dutch cabinet.

The CCC also lobbied the European Parliament and the EU Commission concerning their recent initiatives on codes of conduct and Corporate Social Responsibility.

Pilot projects as a result of company negotiations with the CCC were carried out or are still under way in the Netherlands, in France, Sweden, Switzerland and the UK. under way in the Netherlands, in France, Sweden, Switzerland and the UK.

SOCIAL STANDARDS

The CCC code refers to ILO conventions which also form the standards of the ICFTU Basic Code of Labour Practice of 1997:

- Rights to freedom of association and collective bargaining
- Prohibition of forced labour
- Prohibition of child labour
- Prohibition of discrimination
- Living wage

- Occupational safety and health
- Hours of work
- Establishment of employment relationship (not yet ILO Convention).

SCOPE OF APPLICATION

By signing the CCC Code, retailers and manufacturers declare their responsibility for the working conditions under which the apparel, sportswear and shoes they sell are produced. This responsibility extends to all workers involved in producing goods for the company during the entire manufacturing process – be they employed by the company itself or by the contractor, subcontractor, supplier or licensee.

Observance of the code must be made an enforceable and enforced part of any agreement between the company and its contractors, subcontractors, suppliers and licensees.

MONITORING AND VERIFICATION

Chapter III of the CCC Code deals with the company's implementation and internal monitoring of the code. Chapter IV defines the provisions for independent monitoring, i.e. verification.

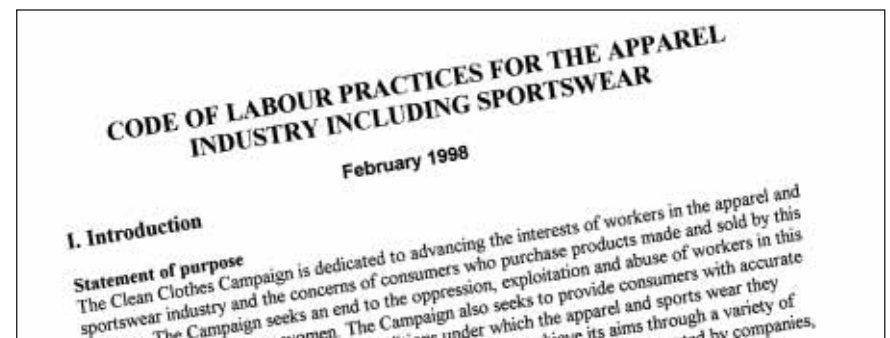

The CCC Code foresees the establishment of an independent institution (foundation) whose board shall be composed of companies, industry associations and employers' organisations on the one hand (50%), and trade union organisations and NGOs on the other hand (50%).

The purpose of the foundation is above all to

- conduct, directly or indirectly through other organisations, the independent verification of compliance with the code,
- assist companies in implementing the code,
- provide means to inform consumers about observance of the code and more generally about labour conditions in the industry.

REPORTING

The accredited monitors shall provide written reports to all parties and to the participating company concerned following each visit. The foundation informs the public about the implementation of the code.

Companies are required to disclose all factory locations in the whole supply chain to the verification body.

COMPLAINTS / APPEALS / CORRECTIVE ACTION

The CCC Code requires the independent foundation to deal with complaints and appeals as well as corrective action. It provides for the termination of a contractual relationship in cases where code provisions are repeatedly violated.

COSTS / FINANCING

The foundation shall be financed by contributions from participating organisations and by payments for services from contracting companies.

CURRENT DEVELOPMENTS

Netherlands

The "Fair Wear Foundation" (FWF), which was established on March 11th 1999, involves the garment retailer associations MITEX and FGHS, the garment supplier association MODINT, the trade union FNV Bondgenoten and its federation FNV, the Dutch CCC, the Zuid-Noord Federatie, the development agency NOVIB and the Max Havelaar Foundation. The chairperson of the board is a former minister. (see box "Board")

The Foundation adopted a code similar to the CCC Code. The larger part of FWF's funds comes from the garment sector: trade unions and employers associations have allocated a contribution to the foundation as part of their Collective Bargaining Agreements. Apart from this, there is a contribution from the development agency NOVIB and an increasing income from fees of member companies.

The FWF parties agreed on a series of pilot projects to identify obstructions in applying the management system, local nitty-gritty aspects of the code, its implementation, and auditing procedures. By 2002, six suppliers of four member companies were tested in India, Indonesia, Poland, and Rumania. In 2003,

BOARD
Chair <i>MARGREETH DE BOER</i> , mayor, City of Leeuwarden
Business associations for garment suppliers <i>HARRY VAN DALFSEN</i> , chair Modint
Business associations for garment retailers <i>BETTY VAN ARENTHALS-KRAMER FREHER</i> , chair Mitex
Labour unions <i>PAUL ANDELA</i> , international secretary FNV Bondgenoten <i>WILLY WAGENMANS</i> , representative FNV Mondiaal
NGOs <i>EVERT DE BOER</i> , chair of the Dutch Clean Clothes Campaign Platform <i>ERIKA SPIL</i> , representative Zuid-Noord Federatie

further pilot projects are planned in China (Hong Kong), Turkey, and other countries.

One of the outcomes of the pilots is that the auditor supervisor or his/her organisation should give more support in the process of implementation of the corrective action plans.

FWF independent verification is carried out in cooperation with networks of partner organisations in countries where garments are produced. These networks consist of representatives of unions, labour-related NGOs, research groups, business associations, the labour inspectorate, etc.

The emphasis of the FWF lies on a continued process of verifying improvements of labour conditions, and not on individual audits. In 2003, it will aim at winning over larger retailers to cooperate with the FWF, to support companies in accomplishing internal monitoring and to lay the ground for an internationalisation of the FWF.

Sweden

In 1998, the Swedish CCC entered into negotiations with the four companies Hennes & Mauritz (H&M), Indiska, KappAhl and Lindex to initiate a common monitoring and verification project. They established a pilot board which carried out preliminary studies and pilot projects in Bangladesh, India, and China in the years 1999–2001. The audits were performed by the "Intertek Testing Services" (ITS) company and the project coordinator in accordance with criteria decided by the pilot board. These criteria included advance interviews by local experts with workers outside the factories, unannounced visits to the factories, etc. Seminars for suppliers were held in Hong Kong, Dhaka/Bangladesh and Tirupur/India. Education and information material on codes of conduct were developed in various languages. The occupational health and training courses originally proposed by a Hong Kong NGO in connection with the China pilot, did not materialise due to the termination of the project.

The pilot projects and the work of the pilot board were exclusively financed by the companies involved.

During the audits, the most serious cases of non-compliance with code provi-

sions were regarding working hours, wages, and freedom of association. The conclusion drawn by the project coordinator was that there should be close cooperation with resource people and organisations in the garment production countries.

In 2002, after completing the pilot projects, preparations for an independent verification structure named "Dresscode" were started. Up to now, however, Dresscode could not be set up due to differing opinions from one of the unions involved.

France

In June 1998, the French CCC («Etique sur Etiquette = EsE») and the retailer Auchan signed a letter of intent concerning a subsequently adopted code of conduct, for which they agreed to work out a system of implementation and independent verification. This included the training of buyers, which has been concluded. The initially planned pilot projects in Madagascar and Vietnam were cancelled, just like the occupational health and safety training in China later proposed by EsE. Auchan unilaterally lowered code of conduct standards, such as for instance the demand of living wages originally agreed with EsE. The French CCC is now discussing the proposal of occupational health and safety trainings in China with toy retailers.

EsE has also been in contact with the French Federation of Retail and Distribution Enterprises (FDC), as well as with Carrefour and Promodès. Lately EsE has started to discuss the possibility of establishing a learning forum with interested companies similar to the Ethical Trading Initiative in the UK.

The projects between French companies and EsE were mainly financed by the companies involved, but EsE also funded part of the costs for the administration. The EU has granted funds to cover a further share of these costs.

Switzerland

In March 2000, the Swiss CCC and the three retailers Migros (the largest in Switzerland), Mabrouc SA/Switcher (now Switcher) and Charles Veillon SA signed the CCC code and decided to carry out a joint pilot project on inde-

pendent monitoring. The project which involved five supplier factories in India and China, started in October 2000 and was completed in January 2003. The pilot project was run by a joint board of representatives of the companies and NGOs, as well as by a project director. Summary reports on the pilot project in India were published at the end of 2002. They listed some improvements, but above all, highlighted a number of continuing problems with management systems, hours of work, overtime pay, and occupational health and safety, in spite of recommendations made after the first inspection visits in 2001.

The pilot project was exclusively financed by the companies involved.

Next to the pilot project, there are currently workers' training courses being held in India and China in cooperation with local partners.

So far the proposed follow-up institution on independent monitoring "Veri" has not found the approval of all stakeholders involved.

United Kingdom

A British CCC affiliate is a member of the Ethical Trading Initiative (ETI). See the profile of ETI below.

Other countries

During the past few years, initiatives towards multistakeholder projects on independent verification were also undertaken in Belgium, Germany and Spain. However, it still remains to be seen if these will result in concrete pilot projects and the establishment of verification institutions. The German Friedrich Ebert Stiftung and the SÜDWIND Institut für Ökonomie und Ökumene (a member of the German CCC) initiated a workers' training programme on codes of conduct in Indonesia with the aim of establishing a code-related network of partner organisations.

COMMENTS

Besides functioning as a mass mobilisation and solidarity organisation, the CCC also acts as a stakeholder in multiparty negotiations with companies. Although these dual functions are considered fundamental pillars of CCC work, they are difficult to combine. Progress has therefore been slow in the field of negotiations with companies. First experiences gained in pilot projects so far are manifold: a) the Fair Wear Foundation policy of cooperating with local partnership networks in apparel production countries, which are composed of representatives of unions, NGOs and labour-related experts, as well as of commercial auditors (sometimes also of labour inspectors) is essential; b) the idea of an institutionalised form of independent verification as a follow-up to pilot projects has not materialised yet in Sweden and Switzerland. Institutionalised verification, however, is considered to be a precondition to a sustained process of improvements. That is why Southern partner organisations of the CCC have repeatedly warned against overestimating first improvements of labour conditions as a result of pilot projects in selected factories.

The CCC strategy conference in March 2001 in Barcelona and the CCC/SOMO Pilot Project Conference in October 2001 in Brussels highlighted the importance of local partnership networks of unions and NGOs in garment supplier countries closely cooperating with CCC networks in industrialised countries. Participants also called for workers' education programmes on labour laws, union rights, codes of conduct, etc. as well as for legal initiatives.

So far the feed-back from partner organisations in Southern and Eastern countries on the overall CCC solidarity work has been very positive. Especially important is the CCC international urgent appeal network which supports workers in the worldwide garment industry in cases of strikes, retrenchments or other conflicts with employers.

4.2 Social Accountability International

GENERAL INFORMATION



In 1997, the Council on Economic Priorities (CEP), a U.S. corporate-responsibility research institute, proceeded to develop the "Social Accountability 8000" (SA 8000) standard on the basis of experience gained with the ISO (=International Organisation for Standardisation) 9000 norm on quality management. CEP's aim was to establish a cross-industry standard for workplace conditions and a system of independent verification. In 1997, CEP founded the "Council on Economic Priorities Accreditation Agency" (CEPAA). The SA 8000 standard was field-tested in five countries. In the summer of 2000, CEPAA was renamed "Social Accountability International" (SAI).



SAI's structure consists of

- the Board of Directors whose 6 members are composed of the SAI President, 1 lawyer, 2 businessmen, 1 businesswomen, 1 NGO person,
- an Advisory Board whose 23 members represent 8 companies, 2 unions, 5 NGOs, the New York City/Office of the Comptroller and the UN Office for Project Services (see table).

The SA 8000 standard is intended for manufacturers/suppliers, but retailers can also adhere to it.

- Manufacturers/suppliers adopt a programme to pursue "SA 8000 Certification"
- Retail and brand companies become "SA8000 Signatories". They publicly announce their commitment to SA8000, seeking out socially responsible and SA8000 compliant suppliers; they assist suppliers in meeting the SA8000 social standards, and provide annual public reports on progress.

There are 9 SAI-accredited Certification Auditors so far: SGS, BVQI, CISE, CSCC, DNV, ITS, RINA S.P.A., RWTUV, TÜV Rheinland Hong Kong.

As of December 31, 2002, 190 facilities have been certified in terms of SA 8000; out of 31 countries represented, China, Italy, India and Brazil figure on top, meanwhile out of 31 industries represented, the apparel/textile and chemical industries make up the largest share.

SA 8000 aims at factory/farm certification. It is a standard for either individual or all production sites owned by a specific company. Although it contains provisions to include suppliers/subcontractors and – "where appropriate" –

SOCIAL ACCOUNTABILITY INTERNATIONAL ADVISORY BOARD MEMBERS

It is SAI's policy to balance its Advisory Board (AB) members equally between business and non-business (non-governmental organizations, trade unions, socially responsible investors and government) members. SAI also seeks to have an international representation on the AB.

Affiliated with Non-Governmental Organizations, Trade Unions, Socially Responsible Investing and Government*:

- DORIANNE BEYER/DAVID ZWIEBEL* (alternate), National Child Labor Committee (USA)
- ODED GRAJEW/HELIO MATTAR* (alternate), Abrinq Foundation for Children's Rights (Brazil)
- The Honorable *WILLIAM THOMPSON/KEN SYLVESTER* (alternate), Office of the Comptroller, City of New York (USA)
- REINHART HELMKE*, United Nations Office for Project Services (UNOPS)
- JAN FURSTENBORG*, Union Network International (Switzerland)
- NEIL KEARNEY*, International Textile, Garment & Leather Workers Federation (Belgium)
- ALICE TEPPER MARLIN*, Social Accountability International (USA)
- MORTON WINSTON*, Amnesty International (USA)
- LYNDA YANZ*, Maquila Solidarity Network (Canada)

Affiliated with Business*:

- IVANO BARBERINI/ALESSANDRA VACCARI* (alternate), Legacoop and Coop Italia (Italy)
- SYLVAIN CUPERLIER*, Dole Food Company (USA)
- TOM DELUCA* (Chair), Toys "R" Us (USA)
- AMY HALL, EILEEN FISHER* (USA)
- PIETRO FOSCHI/ANDREW KIRKBY* (alternate), Bureau Veritas Quality International Holding S.A. (United Kingdom)
- FITZ HILAIRE*, Consultant (USA)
- DR. JOHANNES MERCK/ACHIM LOHRIE* (alternate), OTTO-Versand, (Germany)
- FRITS NAGEL*, WE Europe (The Netherlands)

*Affiliations are for identification only

sub-suppliers, these will only be certified at their own request. However, these provisions do not qualify as an “enforced or enforceable” part of an agreement between a company and SAI. Retailers are generally encouraged to assist suppliers and manufacturers to improve labour conditions.

SOCIAL STANDARDS

With reference to relevant ILO Conventions, the Universal Declaration of Human Rights, the UN Convention to Eliminate All Forms of Discrimination against Women, and the UN-Convention on the Rights of the Child, the SA 8000 standard spells out the following social accountability requirements:

- Freedom of association and the right to collective bargaining
- Prohibition of forced labour
- Prohibition of child labour
- Prohibition of discrimination
- Living wage / compensation including requirements for an established employment relationship
- Occupational safety and health
- Hours of work
- Disciplinary Practices

SCOPE OF APPLICATION

As previously stated, the SA 8000 standard is a factory and farm certification.

Although there are provisions for and recommendations to subcontractors, these do not constitute an enforced or enforceable part of a company's agreement with SAI.

Retailers are generally encouraged to assist suppliers and manufacturers to improve labour conditions.

MONITORING / VERIFICATION

Manufacturers and suppliers can be granted, by accredited certification bodies, the status of “applicants” for one year until they are verified by one of SAI's accredited Certification Auditors. The SA 8000 Certificate must be renewed every three years.

Specially trained local audit teams will be briefed by local NGOs and unions, speak to managers and workers and check the records of the factories. The SA 8000 “Guidance Document” is the SAI manual which assists the accredited auditors in fulfilling this task. NGOs are also encouraged to undergo the process of becoming an accredited SAI auditor.

REPORTING / DISCLOSURE

The audit reports go to the companies and SAI accreditation auditors review a sample and to SAI. Other parties can only receive them after having signed a confidentiality agreement with the company management and the audit company. However, the auditor will pass on the audit outcome to local unions and notify other parties involved in the pre-audit procedures.

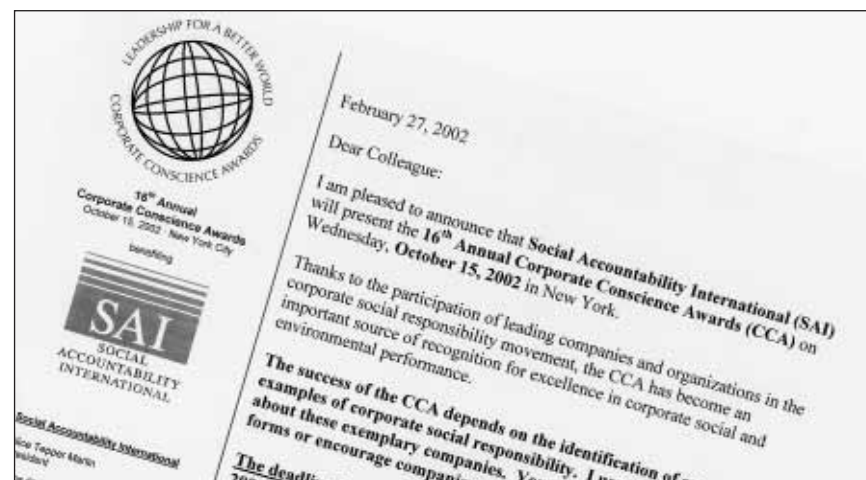

The SAI issues a public list of certified facilities. It requires retailers to annually disclose the number of their certified suppliers and applicants for certification as well as the approximate number of all their suppliers.

COMPLAINTS AND APPEALS PROCESS / CORRECTIVE ACTION

Workers, unions and NGOs can file complaints and appeal against unsatisfactory audit results to the company involved, the certifying body or the accreditation agency.

COSTS / FINANCING

SAI is mainly financed by corporate membership fees, grants from independent foundations and government agencies. For instance, on January 16th, 2001, SAI received US \$ 1 million from the US State Department. In December 2000 the Ford Foundation granted \$ 600,000 for the joint training project with the ITGLWF.

To obtain an SA8000 certification

- a) Certification fees are contractual between applicant and auditor, they vary by country and size of facility.
- b) Per diem audit costs vary between \$ 500 and \$ 1400: up to 12 days are needed for the initial audit of a factory with over 1000 employees.
- c) Travel and translation costs may be incurred, or auditors may be locally based and speakers of local languages.
- d) Every six months, for three years, surveillance audits of an average of three days each.
- e) Improvements of labour conditions, both capital and operating costs – cost varies depending on original status and likely to be larger than payment in 1–4 above.

Accreditation fees are paid by auditing companies for SAI auditing of their performance; initial audit averages 5–7 days, surveillance audits every six months for three years average 4 days. (1)

SA8000 Corporate Involvement Program (CIP) annual fees paid by CIP participants vary by company sales, from US \$ 1,500 to US \$ 15,000, which cover technical assistance, training and report verification.

Level I:	Revenue up to US \$ 25,000,000: annual fee = US \$ 1,500
Level II:	Revenue between US \$ 25,000,001 and US \$ 100,000,000: annual fee = US \$ 3,500
Level III:	Revenue between US \$ 100,000,001 and US \$ 500,000,000: annual fee = US \$ 5,000
Level IV:	Revenue between US \$ 500,000,001 and US \$ 1,000,000,000: annual fee = US \$ 7,500
Level V:	Revenue between US \$ 1,000,000,001 and US \$ 10,000,000,000: annual fee = US \$ 10,000
Level VI:	Revenue of US \$ 10,000,000,001 or more: annual fee = US \$ 15,000

Non-profit organisations are granted a 20% discount.

CURRENT DEVELOPMENTS / COMMENTS

Concerning the social standards, and especially the emphasis on a “living wage” for workers, the SA 8000 norm has been a progressive multi-party code since its inception.

Since the original publication of the SA 8000 standard at the end of 1997, SAI has continuously reviewed the modalities of the “Guidance Document”, corporate applications and membership, and the structure of SAI. At first, the SA 8000 standard was criticised for failing to provide for adequate participation

by unions and NGOs at decision-making levels and because of its very nature as a factory/farm rather than a brand certification system. In factory/farm certification systems, the responsibility for improving working conditions is placed on the producers in developing countries. A factory applying for certification must bear the considerable costs of the process. And although SA 8000 currently calls on retailers to help suppliers implement the standard, it fails to clarify the extent of this support.

The relatively strong position of commercial auditing companies in code of conduct models SAI standard has been met with early criticism for instance by the Hong Kong-based NGO/union coalition LARIC which doubted their ability to perform social audits satisfactorily. (2) Similar doubts were raised by the German SÜDWIND Institut für Ökonomie und Ökumene after it filed a complaint against the SA 8000 certification of the Indonesian factory PT. Pabrik Tekstil Kasrie in December 2001. This certification had been granted although a case of dismissal of workers and union busting in this factory at the time was still pending. SGS handled the complaint without having contacted the union involved or independent experts. However, the complaint procedures have not come to an end yet.

In 2001, SAI and the International Textile, Garment & Leather Workers' Federation started a three-year worker education programme for workers in 12 developing countries.

ENDNOTES

(1) SAI e-mail information January 3rd, 2003

(2) LARIC – “No illusions. Against the global cosmetic SA 8000”, Hong Kong June 1999. (The SAI response to the LARIC Report can be requested by e-mailing SAI).

4.3 Ethical Trading Initiative (ETI)



GENERAL INFORMATION

The ETI in the United Kingdom was launched in January 1998 and formally established in October 1998. The ETI is an alliance of companies, NGOs and trade union organisations that is working to improve labour conditions in the supply chains in Britain. It has adopted the principle of continuous improvement and calls it self a learning forum promoting good practice in implementing codes of conduct, sharing learning with members and the public, as well as measuring impact of implementing the ETI Base Code on the lives of workers. A sizeable grant from the British government helped to establish the ETI (see below “Costs/Financing”).



The ETI uses various instruments: a) the ETI Base Code, which outlines the social standards and the implementation / verification principles; b) pilot studies to compare various monitoring and verification systems; c) programmes to build up union capacities and educate workers; d) research and advocacy work; and e) networking between the North and the South.

The ETI members comprise 28 companies, 15 NGOs and 4 unions (see table).

Its Governing Board comprises 9 members. It is made up of equal representation from the three main categories of members, companies, trade union organisations and NGOs. The Board is directed by an independent chair. The government Department For International Development has an observer status.

Pilot projects have been completed in South Africa, Zimbabwe and China. Pilots are currently being carried out and planned in India, Sri Lanka, Costa Rica, China and other countries. Each member company is expected to cooperate with trade union and NGO members of ETI in at least one pilot project.

ETHICAL TRADING INITIATIVE MEMBERS

Companies

Arbor International
 Anchor Seafood
 ASDA
 The Body Shop International
 Chiquita International Brands
 CWS/The Co-op
 Debenhams Retail
 Desmonds & Sons
 Dewhirst Group
 Fisher Foods
 J. Sainsbury
 Levi Strauss
 Lyons Seafoods
 Lambert Howarth Global
 M&W Mack
 Madison Hosiery
 Marks and Spencer
 Monsoon
 Mothercare
 NEXT
 Pentland Group
 Premier Brands
 Quantum Clothing Group
 Safeway Stores
 Somerfield Stores
 Tea Sourcing Partnership*
 Tesco
 Union Coffee Roasters

Trade unions

International Confederation of Free Trade Unions
 International Textile, Garment and Leather Workers' Federation
 International Union of Foodworkers
 Trades Union Congress

Non-governmental organisations

Africa Now
 Anti-Slavery International
 CAFOD
 Central American Women's Network
 Christian Aid
 Fairtrade Foundation
 Labour & Society International
 Oxfam
 Quaker Peace and Social Witness
 Save the Children
 Traidcraft Exchange
 TWIN
 War on Want
 Women Working Worldwide
 World Development Movement

* The Tea Sourcing Partnership is an association of tea packers comprising Matthew Algie & Co., Brooke Bonde Tea Co., Finlay Beverages, Gala Coffee & Tea, DJ Miles & Co, Nambarrie Tea Co, Keith Spicer, Taylors of Harrogate, Tetley GB, R. Twining & Company, and Williamson & Magor Co.

SOCIAL STANDARDS

The ETI Base Code refers to the relevant ILO conventions. Freedom of associa-

tion, working conditions, wage levels and child labour are regarded as key aspects.

The ETI Base Code alludes to the following ILO conventions:

- Rights to freedom of association and collective bargaining
- Prohibition of forced labour
- Prohibition of child labour
- Prohibition of discrimination
- Living wage
- Occupational safety and health
- Hours of work
- Regular employment relationship
- Prohibition of inhumane treatment.

SCOPE OF APPLICATION

Although the "ETI Base Code Principles of Implementation" spell out the commitment of companies to communicate these principles "throughout the company and to their suppliers and sub-contractors (including closely associated self-employed staff)", the ETI does not require this commitment to be an "enforced and enforceable part of the agreement" between the company and the supplier.

MONITORING / VERIFICATION

Different methods of monitoring and independent verification were tested vs. are currently being tested in the pilot projects in South Africa, Zimbabwe, China, India, Sri Lanka and Costa Rica. (see under "Current Developments/ Comments")

REPORTING

The ETI makes annual performance reports on verification practice and code implementation. The comparative approach of ETI monitoring is also used in the section on "reporting". Companies are expected to report progress to and through the ETI. Special arrangements allow affected workers to make confidential reports on failures to observe the code.

COMPLAINTS / APPEALS / CORRECTIVE ACTION

Workers are provided with confidential means to report failure to observe the code and are otherwise protected in this respect.

Member companies are expected to negotiate and implement agreed schedules for corrective action with suppliers in a continuous improvement approach. In the event of continued serious breaches of the code, the ETI calls on companies to terminate the business relationship with the supplier concerned.

COSTS / FINANCING

The British Department for International Development (DFID) funded the work of the ETI during the 1998–2001 period, covering an earmarked grant of US \$ 850,000 for the work of the secretariat and 50% of the costs for the implementation of the pilot studies. Most of the remaining 50% of pilot study costs are being paid by ETI member companies, with NGOs and unions providing further contributions.

A second three-year grant of the DFID for the period 2002–2004 amounts to US \$ 951,534.

It is the local supplier who is expected to bear the costs of achieving compliance with the ETI code. However, ETI companies are exhorted to pay their suppliers adequate prices for their goods.

CURRENT DEVELOPMENTS / COMMENTS

The ETI Annual Report 2001/2002 relates experiences gained from ETI pilot projects so far as well as outlines of current pilots. Here is a summary:

South Africa Wine Project

This project was set up in 1999 to develop a methodology for multi-stakeholder inspections in the South African wine industry. A tripartite working group in the UK closely worked together with South African trade unions, NGOs, business and academic experts to create, assess and develop such a methodology. Following the completion of the final round of inspections in March 2001, the ETI is now finalising a report documenting the experiences of the participants. As a result of this work, the stakeholders in South Africa decided to develop a local body to carry out inspections using the pilot methodology. The ETI hopes that the South African Department of Labour will endorse the association as a complementary force in improving labour standards in this industry.

The pilot contributed to improvements in working conditions on participating farms, such as upgrades to housing of the workers and a better relationship between management and the workers.

Zimbabwe

The Zimbabwe horticulture project was initiated in 1999 and completed in 2000. The objective was to test commercial approaches to inspecting labour conditions and to compare this to a locally-developed participatory methodology. One outcome of this pilot was the setting up of a local body – the Agricultural Ethics Assurance Association of Zimbabwe (AEAAZ) in 2001. This body carries out inspection and certification of producer farms within Zimbabwe using the methodology developed by the ETI project.

With the support of the ETI, the AEAAZ published a Handbook for Code of Practice Implementers which provides practical guidance and training materials for social auditors. However, due to the overall tense political and social

climate in Zimbabwe, the AEAZ has not been able to be very active during the past months.

China

An initial pilot project was completed in May 2000, but ETI members expressed the need for an ongoing forum to share experiences and work collectively on common issues. A China Working Group established in March 2002 developed a basic guide to improving social conditions, including practical examples of how some members have attempted to create better working conditions. This guide is designated to be updated as experience expands. The China Working Group members also raised awareness of workplace safety and rights in China through experts' presentations and visits to Southern China.

Costa Rica

The Costa Rica Banana Project was initiated in 1999. The objective was to test and compare two approaches to social inspection: a standard commercial approach and a multi-stakeholder approach. After a prolonged planning process, the first two commercial audits were completed in January 2002. Inspection results were reviewed by local and UK stakeholders, and their comments will be presented in a forthcoming report. The second phase will now focus on developing a multi-stakeholder approach.

Two farms inspected in 2002 have implemented plans covering improvements in contracts, health and safety procedures, and housing.

Sri Lanka

The Sri Lanka Project focusing on ready-made garments started in 1999. NGO and trade union members of the ETI had raised questions concerning the validity of audits in identifying problems with working hours and trade union rights in the industry. The pilot therefore aims at investigating ways of applying the provisions of the ETI Base Code in the Sri Lanka garment industry, by developing methods for identifying problems, formulating corrective actions, and as-

sessing their impact. Key achievements in 2002 were the building of bridges between the different stakeholder groups in the UK and in Sri Lanka. A working group with representatives from each of the three membership groups and a local co-ordinator met twice in Colombo to discuss approaches to auditing and how to progress over the coming year.

Further ETI pilot projects are: a) the Child Labour Project in India; b) the Collective Assessment Project in Spain and Kenya which aims at developing an auditing methodology credible to trade unions, NGOs and companies; c) the Smallholders & Homeworkers Working Group which focuses on the tea industry in East Africa and homeworkers in paper products, homewares and other manufacturing/textile in countries like the UK, the Philippines or Indonesia (yet to be decided); d) the Prawns Working Group on the prawn and shrimp industry in India and other Asian countries; e) the Training Assessment Group focusing on the training needs of ETI members.

Overall aims of the ETI during the next months will be to measure its impact on the lives of workers in the supply chain, to extend its membership, build strategic alliances (like for instance with the Dutch Fair Wear Foundation and the Clean Clothes Campaign pilot projects) as well as strengthening the commitment of ETI member organisations.

COMMENTS

The ten completed and current ETI pilot projects offer a broad variety of approaches to the implementation of international labour standards in global supply chains of transnational companies involving commercial auditing and various forms of multi-stakeholder verification. In some instances, progress consisted in building bridges between stakeholders, meanwhile in others it went as far as establishing local inspection bodies and contacts to local governments.

In the case of China, the ETI drew a logical conclusion from a failed monitoring approach in the first pilot in 2000, which was supposed to include unions and

NGOs. The multi-stakeholder verification pilot had failed because the management of the factory concerned did not permit the Hong Kong-based coalition of labour-related organisations to combine the verification process with workers' education. In 2002, the ETI China Working Group embarked on a comprehensive programme of awareness-raising and training between members in the UK and partners in Southern China.

A detailed assessment of the advantages and disadvantages of the different ETI approaches to monitoring and verification has yet to be made. Above all, their impacts on the lives of workers have to be evaluated more thoroughly. This is one of the strategic aims of the ETI in the coming years.

4.4 Fair Labor Association (FLA)



GENERAL INFORMATION

The Fair Labor Association (FLA) was founded in November 1998 on the basis of the Apparel Industry Partnership (AIP), which had been initiated by the White House in August 1996 to address labour rights standards in the US and world-wide apparel industries. The aim of the FLA is to improve working conditions in factories in the garment and sportshoe sector (and other industrial sectors touched by university licensee agreements) in the USA and



When the FLA was founded, the Union of Needletrades, Industrial and Textile Employees (UNITE) and NGOs like the Interfaith Center on Corporate Responsibility (ICCR), all of which had participated in the AIP coalition of companies, unions, NGOs and universities, refused to join the new association. They complained that its social standards and verification principles contained serious flaws.

FAIR LABOR ASSOCIATION

In April 2002, the FLA made important changes in its programme and monitoring procedures with the aim of increasing its transparency, independence, and scope. It agreed to add two new categories of participation – participating agents and suppliers – to its existing categories of companies and college/university licensees. This decision, however, was not meant to change the basic orientation of brand certification of the FLA.

To date, the FLA comprises 13 companies (see table), 178 colleges/universities and 6 prominent human and labour rights organisations like the Lawyers Committee for Human Rights, the National Consumers League, as well as the National Council of Churches.

PARTICIPATING COMPANIES AND LICENSEES

These companies produce in more than 3000 factories in 80 countries, with sales totaling \$30 billion:

adidas-Salomon: All adidas-Salomon footwear, apparel and equipment

Joy Athletic: Joy Athletic apparel

Liz Claiborne: All apparel except licensees and recent less-than-100% acquisitions

GEAR for Sports: All GEAR for Sports products Champion Custom Products

Eddie Bauer: Eddie Bauer apparel

Polo Ralph Lauren: All Polo Ralph Lauren apparel

Patagonia: All products

Nike: All Nike footwear, apparel and equipment

Levi Strauss & Co.: Levi's, Slates and Dockers

Nordstrom: Nordstrom private label apparel

Reebok: All Reebok footwear and apparel

Phillips-Van Heusen: Van Heusen brand, all Van Heusen apparel

Zephyr Graf-X.: All Zephyr Graf-X products

The Board of Directors is composed of representatives of 6 companies, 6 NGOs, 3 universities as well as the chair (see table). The Executive Committee consists of two representatives of companies, two of NGOs, one representative of a university, and a chairperson.

The FLA accredited the following 13 monitors to perform the work of independent external monitoring: ALGI, CSCC, Cotecna Inspections, COVERCO, BVQI, GSC (formerly PriceWaterhouseCoopers), Global Standards/Toan Tin, ITS, Kenan Institute Asia, LIFT-Standards, Phulki, SGS, T-Group Solutions.

FAIR LABOR ASSOCIATION BOARD OF DIRECTORS
Secretary <i>DANIEL R. GLICKMAN</i> , Chair of the Board, Akin, Gump, Strauss
<i>DOUG CAHN</i> , Reebok International Ltd.
<i>BOB DURKEE</i> , Princeton University
<i>BOB EDGAR</i> , National Council of Churches
<i>LINDA GOLODNER</i> , National Consumers League
<i>PHARIS HARVEY</i>
<i>ART HEFFNER</i> , Phillips Van Heusen Corp.
<i>GREGG NEBEL</i> , adidas-Salomon
<i>CAROL KAESEBIER</i> , Notre Dame
<i>DUSTY KIDD</i> , Nike, Inc.
<i>BRUCE MOATS</i> , Levi Strauss & Co.
<i>MICHAEL POSNER</i> , Lawyers Committee for Human Rights
<i>KATHY RODGERS</i> , NOW Legal Defense and Education Fund
<i>JIM SILK</i> , Orville H. Schell Center for Human Rights
<i>RUT TUFTS</i> , UNC-Chapel Hill
<i>BOB ZANE</i> , Liz Claiborne

SOCIAL STANDARDS

The FLA Workplace Code of Conduct addresses the following key issues:

- Prohibition of forced labour
- Prohibition of child labour (age limit is 15 years or 14 where the national law allows)
- Prohibition of harassment or abuse
- Prohibition of discrimination on the basis of gender, race, religion etc.
- Provision of a safe and healthy working environment
- Respect of freedom of association and collective bargaining
- Payment of wages and benefits – at least the legally mandated minimum wages and benefits
- Hours of work: Except in extraordinary business circumstances the hours of work shall not exceed 48 hours per week and 12 hours overtime, or the legally mandated hours per week plus 12 hours overtime
- Overtime compensation should follow legal prescription or – where such a law does not exist – should be at a rate at least equal to the regular hour compensation rate.

SCOPE OF APPLICATION

The FLA Code applies to all facilities of the company itself and those of the suppliers, contractors and licensees with the exception of minimal (“De Minimis”) facilities. The latter are those with which a company contracts production for only six months or less during a 24-month period, or with which the company accounts for only 10% or less of the annual production of such facility. In any event, these minimal facilities shall not constitute more than 15% of all production facilities of a company.

MONITORING AND VERIFICATION

Under the "FLA Monitoring Principles", participating companies agree to internal and external monitoring of every factory, every year – both involving local NGOs on a regular basis. Monitoring takes place in the form of announced and unannounced visits.

Internal company monitoring must cover 50% of all applicable facilities in the first year and all of them in the second year. In the independent external monitoring programme, the FLA staff will conduct annual audits of each company's compliance records and programmes and make field visits. Using a risk assessment methodology, it selects the facilities on a random sample basis to be monitored, and contracts with accredited monitors to conduct the audits, all of which are unannounced. At the end of 2002, the FLA lowered the percentage of externally-monitored facilities to 5% (10% in the initial membership period). The FLA verifies and vouches for the remediation process.

Certification must be reviewed annually.

Labour and/or human rights organisations are encouraged to undergo the accreditation training process.

REPORTING / DISCLOSURE

All internal and external monitoring reports will be provided in full to the FLA staff. The FLA issues annual public reports on the global compliance record of each of its participating companies. In April 2002, the FLA decided to disclose on its website, information related to monitored and independently-verified factories. This information includes the name of the participating company using the factory; the country/region of the factory; the product and size of the facility; the name of the monitor; the findings of non-compliance; the status of remediation.

The companies must provide a complete list of its applicable facilities to the FLA. All FLA schools with licensing programmes have policies that require the public disclosure of factory locations where their licensed products are made.

COMPLAINTS / APPEALS / CORRECTIVE ACTION

Third-party complaints – whether anonymous or public – can be directed to the FLA. There is also a confidential complaints mechanism to the brand company. The complaints must contain reliable, specific and verifiable evidence of information on a case of non-compliance with the Code provisions. The FLA provides for a subsequent process of remediation, after which the third party will be informed of the results.

COSTS / FINANCING

The FLA budget consists of contributions from participating companies as well as from universities and their licensees (formerly also from government and foundations). Companies pay dues ranging from US \$ 500 to US \$ 100,000, according to their annual revenues. University dues consist of 1% of licensing revenues – ranging from a minimum of US \$ 100 and a maximum of US \$ 50,000. In the second year of independent monitoring (July 2002–July 2003), the companies will also pay into a revolving FLA fund to cover the costs of independent monitoring.

According to the FLA principles, all companies in all the categories are responsible for the costs of remediation.

CURRENT DEVELOPMENTS / COMMENTS

In the first year of independent verification (July 2001–July 2002), the FLA verified 185 facilities in 20 countries. Out of the total number of verified facilities, 20 were shared among participating companies demonstrating their readiness to cooperate in order to increase the effectiveness in implementing remediation. The first monitoring/verification reports were expected to be published by the end of 2002, but are still on hold.

To date, there were third-party complaints from El Salvador, Pakistan, and the Dominican Republic which could be dealt with successfully. For instance, on April 19th, 2002, the FLA published a report following a complaint against union rights violations at the factory BJ&B in the Dominican Republic. The FLA took up the case in close cooperation with the Worker Rights Consortium. In the framework of remedial steps, the majority of the retrenched workers were reinstated.

Obviously, the sweeping reforms in the monitoring/verification system and the transparency policy adopted by the FLA in April 2002, were a response to the sharp criticism which had been levelled against the FLA by trade unions and NGOs not only in the USA, but also internationally since its inception. However, the serious flaws in the formulation of social standards in the FLA Charter (e.g. minimum wage instead of living wage requirement) still persist.

The FLA has demonstrated its willingness to explore areas of cooperation with similar code institutions like the WRC, the SAI or the CCC – by inviting each other to conferences, dealing with complaint cases, etc.

4.5 Worker Rights Consortium (WRC)

GENERAL INFORMATION



The Worker Rights Consortium (WRC) was founded on 7 April 2000 in New York on the initiative of "United States Students Against Sweatshops" (USAS).

The WRC goal is to improve labour conditions in the sportswear supplier factories of companies producing goods under licence for US universities (Nike, adidas-Salomon, Reebok etc.). The WRC supports and verifies licensee compliance with the codes of conduct for apparel manufacturers which US colleges and universities have developed in recent years to ensure that the licensed

MEMBERS OF THE WRC GOVERNING BOARD

Representatives of the University Caucus

MARCELLA DAVID (Board Chairperson), University of Iowa

CHRIS HOWELL, Oberlin College

JIM BRUDNEY, Ohio State University

RUT TUFTS, University of North Carolina - Chapel Hill

DOUGLAS SHAW, Georgetown University

Independent Labor Rights Experts

Representing the WRC Advisory Council

MARK BARENBERG, Professor of Law, Columbia Law School

LINDA CHAVEZ-THOMPSON, Executive Vice President, AFL-CIO

REVEREND DAVID DYSON (Board Secretary), Chairperson, People of Faith Network

JILL ESBENSHADE, Associate Professor of Sociology, San Diego State University

KATIE QUAN, Director, John F. Henning Center for International Labor Relations, University of California

Representatives of United Students Against Sweatshops

MATT ABER-TOWNS, Grand Valley State University

AUDREY AVILA, Loyola University

SHAHAR SAPIR, Florida State University

NANCY STEFFAN (Board Treasurer), Indiana University

MATT TEAMAN, Ohio State University

goods sold on their campuses are produced under humane working conditions. The WRC exhorts universities to enforce contract provisions requiring licensee companies to respect basic labour standards. The WRC is not a certification agency.

Next to factory investigation and remediation, the WRC activities also consist of developing a Worker Complaint System, carrying out research and running a factory disclosure database.

The WRC Governing Board consists of 15 members: five representatives each of a) college and university administrations, b) USAS, c) the WRC Advisory Council.

MEMBERS OF THE WRC ADVISORY COUNCIL

RICH APPELBAUM – Professor; Director, Institute for Social, Behavioral, and Economic Research (ISBER); University of California Santa Barbara

JEFF BALLINGER – Director, Press for Change

MARK BARENBERG – Professor of Law, Columbia University Law School

NIKKI F. BAS – Program Coordinator, Sweatshop Watch

ELAINE BERNARD – Director of Trade Union Program, Harvard University

EDNA BONACICH – Professor of Sociology, University of California Riverside

LINDA CHAVEZ-THOMPSON – Executive Vice President, AFL – CIO

TERRY COLLINGSWORTH – Executive Director, International Labor Rights Fund

GINNY COUGHLIN – Union of Needletrades, Industrial, and Textile Employees (UNITE)

REVEREND DAVID DYSON – People of Faith Network

JILL ESBENSHADE – San Diego State University

HOMERO FUENTES – Commission for the Verification of Corporate Codes of Conduct (COVERCO), Guatemala

GIRLIE GUZMAN – Asian Coordinator, Brotherhood of Asian Trade Unions

BEN HENSLER – International Affairs Department, AFL – CIO

GEORGE MILLER – U.S. Representative (D, California)

PEDRO ORTEGA – General Secretary, Federation of Apparel Leather and Textile Workers, Nicaragua

MARITZAH PAREDES – Collective of Honduran Women (CODEMUH)

EBRAHIM PATEL – Southern African Clothing and Textile Workers Union (SACTWO)

KATE PFORDRESHER – People of Faith Network

KATIE QUAN – Director, John F. Henning Center for International Labor Relations, University of California – Berkeley

CAROLINA QUINTEROS – Directora, Grupo de Monitoreo Independiente de El Salvador (GMIES), El Salvador

MONINA WONG – Labor Rights in China, Hong Kong Christian Industrial Committee

JUNYA LEK YIMPRASERT – Thai Labour Campaign, Thailand

The WRC Advisory Council is composed of labour and human rights experts from the USA, Canada and international sportswear producer countries.

As of November 2002, 110 colleges and universities in the USA had joined the WRC.

SOCIAL STANDARDS

The code of conduct developed by the WRC in 1999 is not compulsory for member universities, but they are required to include the following social standards in all other codes:

- Freedom of association – Right to collective bargaining
- Living wages
- A working week of not more than 48 hours
- Overtime compensation according to national law or at least 50% above the normal rate
- Prohibition of child labour
- Prohibition of forced labour
- Occupational safety and health
- Prohibition of discrimination
- Prohibition of harassment or abuse
- Women's rights.

Since current debates about a living wage standard have not yet been satisfactorily resolved, the WRC does not at present insist on such a standard as a condition of membership.

SCOPE OF APPLICATION

The licensee company must present an affidavit declaring that all facilities producing goods under the licensing agreement, including those run by contractors and subcontractors, comply with the code of conduct provisions.

MONITORING / VERIFICATION

As part of the licensing agreement, the universities require licensee companies to ensure implementation and internal monitoring of the code of conduct and render full public disclosure of all production facilities for independent verification. Independent verification by the WRC Agency takes the form of spot investigations taking into account the information produced by the self-reporting and full-public-disclosure commitments of the companies. The WRC Agency operates independently of university licensing offices and industry representatives.

WRC goals do not include the establishment of a comprehensive independent verification regime nor the certification of companies.

Independent verification on a spot-check basis during unannounced visits relies on a network of stable relationships with workers in apparel-producing countries. The WRC is currently developing such a network of contacts with labour organisations.

REPORTING

A licensee company's failure to report, or its reporting of false information, constitutes grounds for a range of sanctions, possibly including termination of the licensing agreement. A company's acceptance of the WRC's full public disclosure requirement means that the WRC will make its reports available to the general public and to worker-allied groups in producing regions.

COMPLAINTS / APPEALS / CORRECTIVE ACTION

The WRC Agency is made responsible for receiving and verifying workers' complaints regarding abuses and violations of the WRC code or relevant university codes. The WRC cooperates closely with worker-allied organisations in verifying these complaints and taking subsequent corrective action.

COSTS / FINANCING

About 40% of the WRC funds derive from a share of the revenues obtained by colleges and universities from licensing agreements and by general contributions. Those colleges and universities with licensing programmes contribute 1% of their licensing revenues, or a minimum of US \$ 1,000 and a maximum of US \$ 50,000. Those without licensing programmes pay US \$ 1,000.

Grants from philanthropic foundations like the Stern Family Fund, the New World Foundation or the Phoenix Fund, make up about 60% of the WRC funds.

The licensee company must foot the bill for implementing and monitoring the code provisions.

CURRENT DEVELOPMENTS / COMMENTS

The WRC uses the licensing agreement applied by US colleges and universities as a lever to enforce labour standards. Since the sale of licensed goods at US colleges and universities is a major cost factor for licensees like Nike, adidas-Salomon or Reebok, these agreements represent a financial tool which the WRC can wield directly to achieve its aims.

The rivalry between the FLA and the WRC for the allegiance of US colleges and universities has decreased in recent months. There were several cases of fruitful cooperation between the WRC and the FLA, like for instance in dealing with complaints from the factories BJ&B in the Dominican Republic and the follow-up to the WRC investigations at the New Era factory in Derby. These steps of cooperation also result from several US schools being members of both, the FLA and the WRC.

In 2001/2002 the WRC, in cooperation with local unions and NGOs, undertook extensive investigations on labour rights violations in licensee supplier factories in a number of countries. These investigations were accompanied by large-scale publicity campaigns, not only at US campuses, but also country-

wide and internationally. They targeted cases of union busting and other labour rights' violations at the Nike supplier factory Kukdong International in Mexico, at the adidas and Top of the World supplier factory PT. Dada in Indonesia, at the BJ & B cap factory in the Dominican Republic, and at the New Era Cap factory in Derby, New York. The WRC investigation reports made international headlines. Substantive improvements were made in these factories due to public pressure, although a number of remedial steps still have to be taken.

4.6 Overview on further code of conduct initiatives

The above-mentioned five internationally prominent codes of conduct in the garment and sportshoe sector do not constitute an exclusive list of important codes of conduct. Several other initiatives also deserve to be discussed in greater detail, but the limited scope of this brochure does not permit more than the following summary of a few examples:

In 1997, the European Association for Textile and Clothing (EURATEX) and the European Trade Union Federation for Textile, Clothing and Leather (ETUC/TCL) signed a **"Charter of the European Social Partners of the Textile and Clothing Sector – Code of Conduct"**, in which they agreed to instruct their member organisations to call on the companies and employees of the European textile and clothing industry to respect the five core labour conventions of the ILO. Together with the ICFTU Basic Code of Labour Practice of 1997, this code of conduct did in fact influence the forthcoming codes in this sector. In principle, however, the Charter between the employer and union federations more closely resembles a framework agreement than the previously described code of conduct initiatives.

In recent months, the **Worldwide Responsible Apparel Production (WRAP)** program which was developed by the American Apparel Manufacturers Association (now American Apparel and Footwear Association) in 1998, has gained much support mainly from apparel manufacturers in Southern countries. To

date, 18 National Manufacturing and Trade Associations from Central America, the Caribbean, Mexico, South Africa, Turkey and Asian countries like the Philippines and Sri Lanka are committed to the WRAP Certification Program. WRAP pursues voluntary, factory-based certification, to be paid for by the factory owners. WRAP has the weakest social standards of all the codes of conduct developed in the USA in recent years. They seldom demand more than compliance with local labour legislation and some of them even offer escape clauses from these laws. The WRAP Certification Board accredits both commercial and non-profit enterprises as external monitors. The members of the WRAP Board of Directors and Officers represent the US apparel manufacturers Sara Lee, VF Corporation, Kellwood and Gerber Childrenswear, as well as non-apparel industry individuals, high-ranking former US Department of Labor officials and a former officer of the now disbanded American Institute for Free Labor Development. Due to its weak social standards as well as lack of transparency and independence, the WRAP program has got little credibility among unions and NGOs. Since June 2000, 330 manufacturers in 32 countries have earned WRAP Factory Certification. By October 2002, 1025 factories from 68 countries have registered to be certified.

In June 2001, the European **Foreign Trade Association (FTA)** and **EuroCommerce** adopted a code of conduct for European companies similar to that of its German member **AVE (Außenhandelsvereinigung des Deutschen Einzelhandels = German Retail Association for External Trade)**. In November 1999, the AVE published a code of conduct which referred in general (weaker) terms to relevant ILO conventions. In 2003–2005, AVE and the German government development agency GTZ will embark on a verification project involving 2500 supplier factories in 15 countries in Eastern Europe and Asia. This pilot will use monitors accredited by Social Accountability International (SAI) and the complaint system of SAI. It will be co-financed by the German government. The FTA/EuroCommerce is lobbying for a joint monitoring system of existing initiatives at EU level.

At the beginning of 2001, a **Round Table on Codes of Conduct** was set up in Germany. Its structure is quadripartite: four seats each for government ministries, business (amongst others AVE), unions and NGOs (such as the German CCC). It aims at improving the implementation of labour standards in developing countries through codes of conduct. To date, the Round Table has limited

itself to collecting experiences of particular stakeholders rather than embarking on common projects.

Yet another variation on the code of conduct theme is the **"Global Alliance"**, which was created in April 1999 by Nike, the World Bank, the International Youth Foundation and several other companies. In 2002, the US retailer company The Gap also joined the Global Alliance. Nike uses the Global Alliance to counteract persistent criticism of Nike's global sourcing policies by labour-related NGOs and unions. These critics have not been soothed by Nike's FLA membership and its support of the UN "Global Compact" initiative. One example of Global Alliance's usefulness to Nike is a study published shortly before the opening of the Sydney Olympic Games in September 2000. Amid a spate of press reports about poor working conditions at Nike supplier factories in Indonesia, the study by the "Global Alliance for Workers and Communities" painted such a favourable picture of labour conditions for 3,800 workers in 12 Nike supplier factories in Thailand and Vietnam that critics dismissed it as a whitewash. At the beginning of 2001, a report on labour conditions in nine Nike contract factories in Indonesia published by the Global Alliance hit

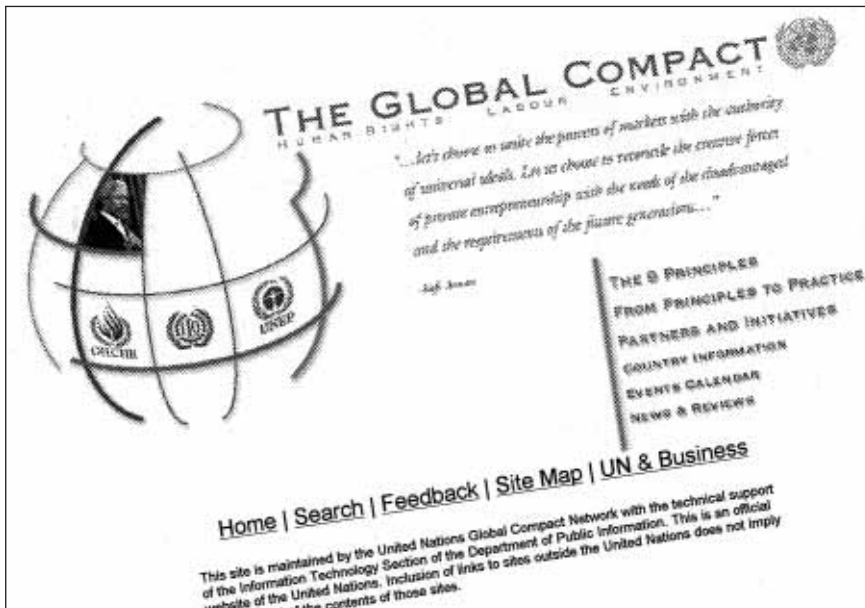

international headlines. The self-criticism of Nike with regard to massive labour rights violations in these factories, and its vow to implement remediation plans were remarkable. However, the follow-up report, promised to be published a year later, is still on hold. Besides workplace issues, the company-driven Global Alliance also deals with educational, health, nutritional, and life skills and development programmes in developing countries. Its initial budget was US \$ 10 million. At the end of 2002, the Global Alliance was active in 48 factories on Thailand, India, Indonesia, and Vietnam representing a workforce of 167,000.

The **International Organization for Standardisation (ISO)** has initiated a process of discussing ISO Corporate Responsibility instruments taking into account the experiences from its quality management system standards (ISO 9000) and its environmental managements system standards (ISO 14000).

At the World Economic Forum held in Davos in January 1999, UN Secretary General Kofi Annan proposed a new initiative in support of responsible business operations and universal values under the name of the **"Global Compact"**. It is a joint initiative of leading representatives of business, labour and civil society. Its principles refer to the Universal Declaration of Human Rights, the ILO's Fundamental Principles on Rights at Work and the Rio Principles on Environment and Development. So far 649 companies including Nike, Daimler Chrysler, Royal Dutch/Shell Group, Unilever, Rio Tinto, Deutsche Bank, Bayer and business associations like the International Chamber of Commerce have publicly pledged to support the Global Compact.

It requires companies to publish annual reports and display on their websites specific examples of progress in putting the principles of the Global Compact into practice. It also allows NGOs to publicly challenge the companies involved. The Global Compact also aims at contributing to the UN Development Millennium Goals through Partnership Projects. It organises Annual Learning Forum Meetings and reaches out to the international community through Local Network Structures.

Useful as it may be as a dialogue platform, the Global Compact has already provoked sharp criticism from those who struggled for many years to promote more effective ways to improve human rights standards in the subsidiaries and supplier factories of transnational corporations. The poor human rights and labour records of some of the signatories like Nike, Shell and Bayer have

been publicly exposed time and again. The Global Compact is a non-binding agreement which lacks any enforcement mechanism. It is therefore doubtful whether input from those who suffer most from human rights violations along the production chain of the companies involved will receive adequate attention.

In June 2000 the **OECD** revised the **Guidelines for Multinational Enterprises** which it originally published in 1976. They still do not legally bind companies concerned. Instead, they define the expectations of the adhering governments of both OECD member nations and non-associated countries. Although the new guidelines include several new topics such as sustainable development, human rights, environmental management, child and forced labour, bribery and corruption, they remain weak on a number of other issues like consumer relations, the promotion of nuclear power, genetic modification etc. The OECD calls on NGOs and the public to intensify their participation in checking the implementation of the OECD Guidelines by cooperating more closely

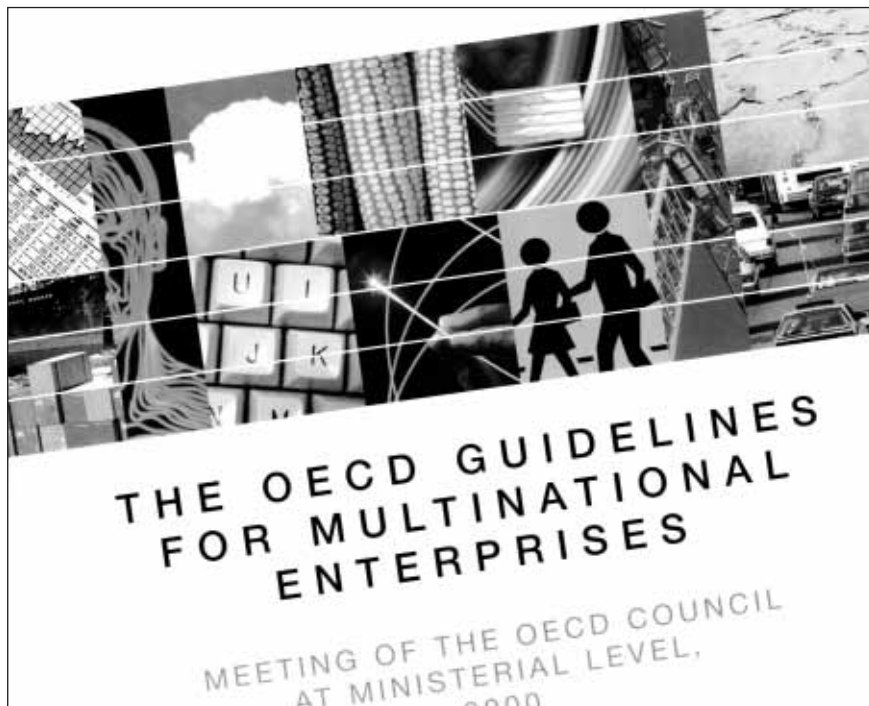

with the National Contact Points in the OECD member states. To date, more than 20 cases have been raised with National Contact Points in OECD countries. The structure of National Contact Points varies from single department to multi-department (tripartite, quadripartite) in different countries. Meanwhile there were few successful cases of National Contact Points that did function, for instance, in France and the Czech Republic, in other countries like in the USA, cases were not handled effectively. At a meeting of the OECD on 17th June 2002 in Paris, it was stated that there were still too many dormant National Contact Points, and that many failed to consult with unions and other interested parties. In their response to the publication of the revised OECD Guidelines, 75 NGOs urged adhering governments to regard these guidelines as no more than a first step in the right direction. They specifically stressed the need for implementation mechanisms designed to guarantee global application.

On May 31st, 2002, in a second prominent initiative on codes of conduct, the European Parliament voted for new legislation to require companies to publicly report annually on their social and environmental performance, to make Board members personally responsible for these practices, and to establish legal jurisdiction against European companies' abuses in developing countries. However, in its response to the Parliament's vote published in July, the European Commission firmly rejected a regulatory approach to corporate social responsibility (CSR) emphasising the voluntary nature of CSR. The White Paper of the Commission rejects mandatory social and environmental reporting, compulsory social labelling of products and any regulation requiring pension funds in member states to disclose any socially responsible investment policies. The Commission emphasises its role in helping to promote CSR management skills, develop means of sharing best practice and introduce an ethical dimension to its own procurement policies. A "Multistakeholder Forum on CSR" comprising 40 representatives from businesses, trade unions, consumer groups and NGOs was set up to oversee the White Paper's recommendations.



4.7 Overview and Comparison

OVERVIEW OF MAIN FEATURES OF CCC, SAI, ETI, FLA, WRC

	CCC	SAI		ETI	FLA	WRC
INITIATIVE/ YEAR OF FOUNDATION	Dutch research institute SOMO 1990.	US-American consumer Organisation CEP 1997.		Various NGOs 1998.	Clinton Administration 1996.	US-American students'Organisation USAS 2000.
AIMS AND OBJECTIVES	Improvement of labour conditions in the worldwide garment / sportswear industry.	Improvement of labour conditions in all industries (except mining).		Improvement of labour conditions in the worldwide garment and food industry and in horticulture.	Improvement of labour conditions in the worldwide garment industry and all industries producing under license for US universities.	Improvement of labour conditions in the worldwide garment industry producing under license for US universities.
METHODS/ INSTRUMENTS	<ul style="list-style-type: none"> a) Code of Labour Practices – independent verification body, certification of member companies including whole supply chain, b) Legal initiatives, cooperation with government structures, c) North-South solidarity, d) Information of consumers. 	<ul style="list-style-type: none"> a) SA 8000 Standard - independent verification, certification of producers /suppliers, b) 2001 - 2004 worker education programmes in cooperation with ITGLWF. 		<ul style="list-style-type: none"> a) Member companies committed to implementation, monitoring and verification of ETI Base Code in whole supply chain, b) Multistakeholder learning forum: comparison of different monitoring and verification models, c) Research and North - South advocacy, d) Networking between northern and southern groups. 	Workplace Code of Conduct – independent verification, certification of participating companies/licenses including whole supply chain.	<ul style="list-style-type: none"> a) Code of Conduct – no certification of licensee companies, but spot-check inspections in whole supply chain. Investigation and remediation reports. Standard setting for license agreements of US universities, b) Networking North-South, campaigns.

OVERVIEW OF MAIN FEATURES OF CCC, SAI, ETI, FLA, WRC

	CCC	SAI		ETI	FLA	WRC
MEMBERSHIP/ GOVERNANCE	More than 250 NGOs and unions in 14 autonomous CCCs with differing governance structures in 12 European countries. International Secretariat in Amsterdam.	a) Board: 2 NGO, 1 lawyer, 3 companies, b) Advisory Board: 5 NGOs, 2 unions, 1 UNO, 1 New York City, 8 companies.		a) Members: 29 companies, 15 NGOs, 4 unions (government), b) Board: 3 companies, 3 NGOs, 3 unions, 1 chair. (Government observer status).	a) Members: 13 companies, 6 NGOs, 178 universities, b) Board: 6 companies, 6 NGOs, 3 universities, 1 chair, c) NGO Advisory Council.	a) Members: 110 universities, USAS, b) Board: 5 universities, 5 USAS, 5 Advisory Council, c) Advisory Council: 22 experts.
SOCIAL STANDARDS	a) Freedom of association, b) Collective bargaining, c) No forced labour, d) No child labour, e) No discrimination, f) Living wage, g) Occupational safety and health, i) Hours of work, j) Establishment of employment relationship. (Reference to ILO Conventions and to ICFTU Code of 1997).	a) Freedom of association, b) Collective bargaining, c) No forced labour, d) No child labour, e) No discrimination, f) Living wage, g) Occupational safety and health, h) Hours of work, i) Management systems. (Reference to ILO and to UN Human Rights / Child/Women/ Conventions).		a) Freedom of association, b) Collective bargaining, c) No forced labour, d) No child labour, e) No discrimination, f) Living wage, g) Occupational safety and health, h) Hours of work, i) Establishment of employment relationship, j) No inhuman treatment. (Reference to ILO).	a) Freedom of association, b) Collective bargaining, c) No forced labour, d) No child labour (except 14 years if legal), e) No discrimination, f) Legal minimum wage including benefits, g) Occupational safety and health, h) Hours of work (exceptions from ILO- 48 h. plus 12 h. overtime/ week- possible), i) Overtime pay possible at normal rate, j) No harassment or abuse.	a) Freedom of association, b) Collective bargaining, c) No forced labour, d) No child labour, e) No discrimination, f) Living wage, g) Occupational safety and health, h) Hours of work, i) Establishment of employment relationship, j) No harassment or abuse, k) Women's rights.





OVERVIEW OF MAIN FEATURES OF CCC, SAI, ETI, FLA, WRC

	CCC	SAI		ETI	FLA	WRC
SCOPE OF APPLICATION	<p>The whole supply chain of garment products including contractors, sub-contractors, suppliers and licensees.</p> <p>(Enforceable and enforced part of any agreement).</p>	<p>Emphasis on factory/farm, but also recommendations for supply chain.</p>		<p>The whole supply chain of garment, food and horticulture products including contractors, sub-contractors, suppliers and licensees.</p>	<p>The whole supply chain of garment products including contractors, sub-contractors, suppliers and licensees, with the exception of "minimal" facilities (short-term suppliers and small volumes).</p>	<p>The whole supply chain of garment products including contractors, sub-contractors, suppliers and licensees.</p> <p>(Enforceable and enforced part of any agreement).</p>
MONITORING/ VERIFICATION	<p>Brand certification / orientation.</p> <p>Verification institution with board of 50% company and 50% NGO/ union representatives, contracts with audit companies possible.</p> <p>Since '99 Dutch "Fear Wear Foundation" (incl. CCC), multi-stakeholder verification in cooperation with partner networks in garment production countries (unions, NGOs, business, labour inspectorate). Principle of continuous improvement.</p>	<p>Factory/farm certification. 9 SAI accredited audit companies (SGS, BV-QI, ITS etc.) verify producers according to SA 8000 Guidance document (consultation with NGOs and unions).</p> <p>NGO auditors also possible.</p> <p>SA 8000 certificate is valid for 3 years. Surveillance audits every 6 months.</p>		<p>Brand orientation.</p> <p>Multistakeholder learning forum - comparison of different monitoring and verification models and pilot projects since 1999. Principle of continuous improvements.</p>	<p>Brand certification.</p> <p>Annual monitoring and verification.</p> <p>As from 2nd year onwards, internal monitoring of all facilities in supply chain, independent verification in 5% of all facilities (10% in the initial membership period).</p> <p>All internal and external monitoring in consultation with local NGOs.</p> <p>13 accredited audit companies (BVQI, SGS, Verité etc.).</p>	<p>Brand orientation.</p> <p>WRC Agency undertakes spot-check inspections in selected licensee supplier factories.</p> <p>Investigation and remediation reports.</p> <p>Licensee companies are required to disclose all production facilities.</p>

OVERVIEW OF MAIN FEATURES OF CCC, SAI, ETI, FLA, WRC

	CCC	SAI		ETI	FLA	WRC
REPORTING/ DISCLOSURE	<p>After each inspection audit reports go to all parties involved and to the participating company.</p> <p>The verification body informs the public.</p> <p>Companies must disclose factory locations in the whole supply chain to the verification body.</p>	<p>Audit reports go to SAI and to the companies. Other parties can get audit reports after having signed a confidentiality agreement. Auditors inform consulted NGOs and unions about the outcome.</p> <p>Public list of certified facilities .</p>		<p>Pilot reports go to the ETI.</p> <p>ETI informs the public annually about the verification results.</p>	<p>Internal and independent monitoring reports go to the FLA staff.</p> <p>Annual public reports about every participating company, university and its licensees.</p> <p>Public information on monitored/verified factories.</p> <p>Companies disclose full list of applicable facilities to FLA. Schools publicly disclose factory locations of licensed products.</p>	<p>WRC verification and remediation reports go to all parties involved.</p> <p>Disclosure of all production facilities of licensee suppliers.</p>
COMPLAINTS/ APPEALS/ CORRECTIVE ACTION	<p>Complaints/Appeals go to the foundation which initiates corrective action. Decisions are taken after consultation with the parties concerned.</p>	<p>Complaints/Appeals can go to:</p> <ul style="list-style-type: none"> a) the management of the factory, b) the certifying body, c) the accreditation agency, <p>each of them being able to initiate corrective action.</p> <p>Objections are being dealt with by the higher level bodies.</p>		<p>Complaints/Appeals go to ETI which then initiates corrective action in a process of continued improvement.</p>	<p>Third-party complaints go to FLA which then informs those who filed the complaints/appeals about the outcome of corrective action.</p> <p>Also possible complaints direct to brand companies.</p>	<p>The WRC Agency examines the complaints/appeals and initiates corrective action in cooperation with labour organisations.</p>

OVERVIEW OF MAIN FEATURES OF CCC, SAI, ETI, FLA, WRC

	CCC	SAI	ETI	FLA	WRC
Costs/ FINANCING	<p>Participating companies and organisations contribute to the administration costs of the independent verification body.</p> <p>Pilot projects mainly paid by companies.</p> <p>Corrective action should be paid primarily by transnational corporations.</p> <p>Dutch Fair Wear Foundation (incl. CCC) is financed by membership fees, by NOVIB and parts of Collective Bargaining Agreements.</p>	<p>Annual fees for member companies vary between US \$ 1,500 - 15,000 according to revenues. Funds from government and foundations.</p> <p>Producers and suppliers pay for the SA 8000 certification: per diem audit costs, travel and translation costs. (minimum US \$ 13,500 and maximum US \$ 37,800 in 3 years without travel and translation costs).</p> <p>The costs for corrective action are paid by the producer.</p>	<p>The Blair government contributed US \$ 850,000 for 1998-2001 and US \$ 951,534 for 2002-2004.</p> <p>The second important source of income are membership fees.</p> <p>The costs for corrective action should be paid by the producers. However ETI refers to possible member companies' contributions through new pricing systems.</p>	<p>Administration costs are paid by annual company fees (between US \$ 500 - 100,000 according to revenues), contributions by universities (1% of licensing revenues = between US \$ 100 - 50,000 per year).</p> <p>FLA participating companies/licensees are responsible for the costs of remediation.</p>	<p>Administration costs are paid by the fees of member universities: 1% of annual licensing revenues (between US \$ 1,000-50,000).</p> <p>Funds from foundations.</p> <p>The licensing company shall pay for the costs of the improvement of labour conditions and of the monitoring and verification.</p>
					

OVERVIEW OF MAIN FEATURES OF CCC, SAI, ETI, FLA, WRC

	CCC	SAI	ETI	FLA	WRC
CURRENT DEVELOPMENTS	<p>Dutch "Fair Wear Foundation" (incl. CCC) pilot projects completed in India, Indonesia, Poland, Rumania and planned in Hong Kong/China, Turkey etc.</p> <p>Pilot projects of CCC Sweden (India, Bangladesh, China) completed, independent verification body on hold.</p> <p>Pilot projects of CCC Switzerland in India and China completed, independent verification body on hold.</p> <p>CCC France: after cooperation with Auchan now planning learning forum.</p> <p>Round Table on Codes of Conduct in Germany with CCC.</p> <p>Work with the Code next to public campaigns, legal initiatives, cooperation with governments, North-South solidarity work.</p>	<p>To date 190 certifications of factories in 31 countries and 31 industries.</p> <p>Cooperation with AVE/GTZ Germany on verification of 2500 factories in 15 countries in 2003–2005.</p> <p>2001–2004 worker education programmes in 12 developing countries in cooperation with ITGLWF.</p>	<p>Pilot projects in South Africa, Zimbabwe and China completed. Currently 7 pilot projects in Costa Rica, Sri Lanka, India etc.</p> <p>Research programmes, advocacy and networking between North and South.</p>	<p>In the first year of independent verification (July 2001 - July 2002), 185 facilities were independently verified in 20 countries.</p> <p>The FLA Charter is currently under revision.</p>	<p>Follow-up to 4 main investigations – remediation reports (Mexico, Indonesia, USA, Dominican Republic).</p> <p>Factory Database updates.</p> <p>Further establishment of North-South contacts, networking.</p>

COMPARISON

Along the same lines as the earlier section on code profiles, the following comparison of the five prominent codes of conduct in the apparel and sportsshoe sector concentrates on key features without going into subsidiary details.

→ INIATIVE, AIMS, METHODS, MEMBERSHIP, STRUCTURE

The strongest grass-root driven **initiatives** are the Clean Clothes Campaign (CCC) and the Worker Rights Consortium. The US consumer organisation "Council on Economic Priorities" (CEP) developed the SA 8000 standard with explicit reference to the International Organisation for Standardisation (ISO), the chief author of international corporate norms in the private sector. Two projects resulting from government interventions are the FLA and ETI, which were respectively fathered by the Clinton Administration and the Blair government.

All five codes of conduct share the **goal** of improving labour conditions in the world-wide apparel and sportsshoe industry. However, the FLA, the ETI and SA 8000 do not confine themselves to this industrial sector. The FLA also addresses companies in other sectors which manufacture licensed products for US colleges and universities. The ETI's field of activity also includes the food, beverage, and horticulture sectors.



SAI is a cross-industry project including agriculture, although it has not yet addressed the mining sector.

Whereas the ultimate goal of the CCC, FLA and ETI is **brand certification/ orientation**, SAI standard envisages **factory and farm certification**. Although the WRC explicitly

does not intend to certify "good" licensee companies, the underlying logic here too is brand-oriented and not factory-oriented.

The divergence between brand versus factory certification reflects different responsibilities concerning compliance with code standards, which in turn implies different cost dimensions. (see below under "Costs/Finance")

Among various **methods** used to achieve better labour conditions, those of the CCC are the most versatile. Its code of conduct is only one of several CCC instruments, the others being consumer conscientisation, legal initiatives and direct solidarity with workers' organisations. The WRC has almost equally varied functions: besides negotiating with university administrations, it also organises demonstrations, speaking tours, etc. The ETI, apart from testing schemes to monitor its Base Code provisions, also conducts research, workers' education programmes, advocacy and networking between Northern and Southern countries. The FLA and the SA 8000 models require no campaigning activities since they concentrate on the implementation and verification of their code provisions. In 2001, SAI, in cooperation with the ITGLWF, also embarked on a worker education programme in 12 developing countries.

In the five models, the composition of the **membership** varies with the case-to-case existence or strength of representatives of the four stakeholder categories, i.e. industry, government, unions and NGOs. The WRC is the only code with no industry representatives. In turn, the FLA – unlike the other four codes – has no union members. NGOs are represented in all five models. With the exception of one seat in the SA 8000 Advisory Board, the **structures** of all five models exclude direct public-sector representation, although government involvement in the ETI and the SAI is made obvious by public grant funding. The majority of industry in the overall membership of the SAI, the FLA and the ETI is balanced by equal representation of all stakeholders in key structures. Due to its original role as a campaigning organisation, the CCC's progress towards involving companies in negotiations and pilot plants has been slow. However it has managed to include the industry associations in the Dutch "Fair Wear Foundation", three retailers in the 2000–2002 pilot project in Switzerland, and four retailers in the 1999–2001 pilot project in Sweden.

→ SOCIAL STANDARDS

Unlike the FLA, the four other code models have very similar sets of social standards. By and large, these reflect the standards contained in the ICFTU Basic Code of 1997. The FLA code has been widely criticised for the following flaws: it requires no more than the legal minimum wage, allows for exceptions from the maximum 60-hour work week in peak periods and permits less than generally defined levels of overtime compensation. However, since the FLA considers itself to be a “work-in-progress”, it has already responded to severe public criticism promising to reconsider wage levels in the future.

→ SCOPE OF APPLICATION

The scope of application varies considerably in the five codes.

The CCC and WRC codes contain the most sweeping provisions, while those of the FLA code are the most limited.

The CCC code, modelled on the ICFTU Basic Code, covers the signatory company's entire supply chain including contractors, subcontractors, suppliers and licensees. Observance of the CCC code must be an enforceable and enforced part of any agreement between the signatory and its contractors, subcontractors, suppliers and licensees.

The WRC code likewise covers the entire supply chain of a licensee company and requires it to present an affidavit declaring that contractors and subcontractors comply with the code of conduct.

SAI standard also covers the supply chain of a member or certified company, but its goal is factory and farm certification; it fails to require compliance with the code provisions as an “enforceable and enforced part” of any business agreement with contractors, subcontractors, suppliers and licensees.

The ETI code is applicable throughout the company and its suppliers, although not in legal terms. Moreover, ETI information material is more vague in stating that “member companies are committed to the adoption of the ETI Base Code **for all or part** of their business.”

The FLA code applies to all facilities of the company itself and those of the suppliers, contractors and licensees with the exception of “minimal” facilities. This exception e.g. allows factories working under contract for up to six months in a 24-months period to escape the provisions of the FLA code – a serious flaw in view of the widespread use of short-term contract work in the world-wide garment industry.

→ MONITORING / VERIFICATION

All five code models foresee internal company monitoring as a first step towards independent third-party verification. However, the crux of the international debate is the “independence” of the verification. The litmus test of the independent nature of the verification is the degree of involvement of the workers concerned, their unions and labour-related NGOs. This involvement boils down to their representation in the main bodies of the code institutions and their integration into the verification process, as well as, into the appeals and complaints procedure (for the latter: see below).

To varying degrees, the CCC, SAI, ETI and WRC have ensured the participation of unions and NGOs in their policy structures. The FLA's credibility suffers from the absence of unions in its structure.

Criticism has been voiced against the high-key use of commercial auditing companies like SGS or BVQI for the independent verification exercises of SAI. Sometimes it is principally argued that these companies cannot meet the special demands of independent auditing because they have no record of dealing with labour. It is indeed difficult to believe that workers will shed their inhibitions towards auditors who have traditionally been as closely identified with management as SGS and BVQI. However, much depends on the auditing instructions and the function of audits in the whole verification process. If, for instance, the commercial auditing is combined with NGO/union-related auditing schemes and verification like for instance in the Dutch Fair Wear Foundation, this criticism will not necessarily be valid. Both the FLA and SAI invite NGOs to undergo auditor training courses and become auditors themselves. But this too will not be helpful unless the entire verification framework seems sufficiently trustworthy to the workers and their organisations.

The independent verification system of the FLA was much improved through its reform programme of April 2002. It is now the FLA, and not the companies, which selects the facilities to be monitored, contracts with accredited auditors and vouches for the remediation process.

The ETI's verification system continues to be tested in pilot projects. The tests comprise internal company monitoring, commercial auditing, verification by academics and verification based on participation by unions and NGOs as well as mixed systems.

The WRC does not use commercial auditors for independent verification purposes. Instead, student delegations are sent to producer countries to build up a network of independent verifiers for the envisaged WRC spot-check investigations.

Considering that the first monitoring and verification exercises, and pilot projects were started as recently as 1998, it is much too early to fully assess the validity of any of the five code models.

→ REPORTING / DISCLOSURE

Procedures for handling internal monitoring and independent verification reports are not fully spelled out in all of the five code models. Whereas the FLA and the ETI clearly state that all reports must be forwarded both to the companies concerned and the FLA and ETI executives, which must then prepare summaries for the public, the WRC states that all reports are to be made public. The CCC code requires written reports by the accredited monitors to be provided to "all parties and to the participating companies" – without specifying whether summarised versions will suffice in some cases. SAI directs auditors to send reports to the company and to the SAI. Parties which have signed an agreement of confidentiality receive full reports; others receive summaries.

The disclosure of factory locations – an issue of key significance for the credibility of a code of conduct – is handled differently in the five code models. Disclosure and transparency make it possible to determine what percentage of a company's total number of factories has been certified. Disclosure can thus reveal whether certification of only a few supplier factories is likely to be

misused to deceive the public about the company's overall performance.

The WRC demands full public disclosure of all factory locations. The CCC links the same demand to a requirement for comprehensive transparency on all other relevant levels. In 2002, the FLA decided to lower the percentage of independently verified facilities of companies to no more than 5% (10% in the initial membership period). But companies must provide a complete list of its applicable facilities to the FLA, and all schools in the FLA with licensing programmes have policies that require the public disclosure of factory locations where their licensed products are made. SAI issues a public list of certified facilities and requires retailers ("SA 8000 Signatories") to annually disclose the number of their certified suppliers and applicants for certification as well as the approximate number of all their suppliers.

→ COMPLAINTS / APPEALS / CORRECTIVE ACTION

It is crucially important to provide for an independent body to which workers or their representatives can direct complaints and appeals. All five code models specify procedures allowing workers and interested parties to submit their complaints and appeals – anonymously and publicly – to the main policy-making bodies. Since unions are not represented in the FLA, the workers, however, will find it difficult to trust its complaint and appeal procedures.

Although there is not much experience yet with existing complaints and appeals systems in the five code models, some few interesting cases deserve attention. During the WRC investigations on the Mexican factory Kukdong, the Indonesian factory PT. Dada, the BJ & B factory in the Dominican Republic, and the US factory New Era, workers, unions and NGOs involved made ample use of the complaints system once the preliminary findings and recommendations of the WRC had been made public. The improvements of labour conditions in these factories are an immediate result of the ensuing interactions.

A complaint against union repression at the BJ & B factory in the Dominican Republic was filed with the FLA at the beginning of 2002. The FLA published a report and intervened – in cooperation with the WRC. In the framework of remediation, the majority of the retrenched workers were reinstated.

The complaint of the German SÜDWIND Institut für Ökonomie und Ökumene against the SA 8000 certification of the Indonesian factory PT. Pabrik Tekstil Kasrie which was filed in December 2001, has been unsatisfactorily handled by the SAI accredited audit company SGS. Following the complaint, SGS did not contact the union concerned by the dismissals of its members at this factory, nor independent experts. But the complaint case is not closed yet.

→ COSTS / FINANCING

Distinctions must be made between the normal budget costs of the five code institutions, certification costs and those of remedial action. Not all of the five codes deal explicitly with these three aspects. These deficiencies will have to be overcome in the future.

According to SAI, factories/farms pay for their certification, although so far signatory companies have paid audit fees in various cases. Prompted by the logic of brand certification/orientation, the FLA, ETI, and CCC state that the affiliated companies must pay for the certification of their suppliers (factory certification is not a WRC goal).

Concerning remedial action, the WRC states that the costs involved must be borne by the licensee company. The CCC code clearly points in the same direction by emphasising the responsibility of those at the end of the supply chain – i.e. the transnational corporations – for working conditions. The SAI vaguely calls on retailers to assist their suppliers in meeting international standards. The FLA states that the brand companies are responsible for remediation. The ETI states that the suppliers will have to bear these costs, but requires retailers to pay their suppliers adequate prices for their products, while setting favourable sourcing conditions (e.g. reliable medium-term order schemes) to allow the suppliers to implement the required social standards.

The sourcing structure of the revenues which cover the daily running costs of the five code institutions shows the following variations:

- Membership fees constitute an essential part of the budget in all five code models,

- The Fair Wear Foundation is the only one to be financed by parts of Collective Bargaining Agreements,
- Currently, the SAI and ETI receive government funds,
- SAI and WRC also get grants from foundations.

→ CONCLUSION

All five code models are recent enough to be still in the making. Nevertheless, as an initial assessment, in spite of a number of similarities, it is also useful to sum up some of the more striking differences identified in the preceding comparison:

- Especially the CCC commands other key instruments besides their codes of conduct and training/research programmes. These tools include legal measures and direct solidarity action.
- The principle of brand membership in the ETI and Fair Wear Foundation stands opposed to the principle of certification in SAI and the FLA.
- Stakeholder participation in the FLA, which lacks union partners, is less representative than in the other four code models.
- As opposed to brand certification/orientation, the SA 8000 standard shifts the brunt of responsibility for improving working conditions from TNCs to third world supplier factories.
- The set of social standards in the FLA charter contains serious flaws.
- Commercial auditors with hardly any record in social auditing, occupy a key position in the SAI system.
- Independent verification of the CCC and ETI foresees close cooperation with local structures in production countries and with private auditing firms.
- The WRC model can deploy a powerful boycott weapon against companies which fail to comply with its code provisions – i.e. cancellation of the licensee agreement. The sanctions envisaged by the brand certification/

orientation models consist of consumer and media pressure or withdrawal of the certificate – a less stringent economic weapon which may nevertheless prove effective if public pressure can be maintained.

During the past few years, convergence has grown in some areas of the policy and activities of the five code models. The future challenge will be to explore more common ground in order to strengthen the impact of these tools.

The outcome of this comparative evaluation of the five code models prompts another question: what strategic options are available to apply codes of conduct?



5. Perspectives

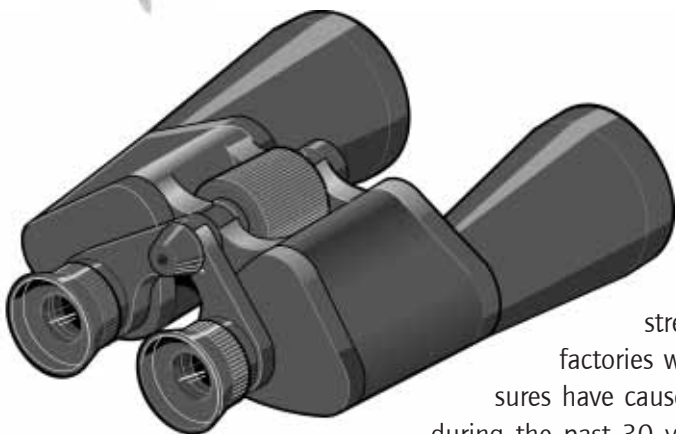

Codes of conduct enable workers to strengthen their power in factories where globalisation pressures have caused them to lose ground during the past 30 years, – but only if they know their advantages and limitations.

Codes of conduct can be useful tools to implement social standards if they fulfil certain conditions and are part and parcel of broader political activities. To achieve their immediate aims, codes of conduct must fulfil the following criteria:

a) Substance

The social standards catalogue should not undershoot the Basic Code of Labour Practice of the ICFTU, which is more comprehensive than the core labour standards of the ILO. The key standards here are the rights to freedom of association and collective bargaining.

b) Participation

Codes of conduct can only function well if the stakeholders concerned are full partners at the relevant decision-making levels of the code institutions, i.e. companies, unions and labour-related NGOs.

c) Social responsibility in the production chain

Powerful actors in world trade must live up to their responsibility for labour conditions in the global production chains. They must reflect this responsibility in applying the codes of conduct. This requires transnational corporations to make decisive contributions to the improvement of labour conditions along the whole supply chain – including subcontractors and homework.

d) Independent verification

Corporate implementation and monitoring of codes of conduct must be verified by independent multi-stakeholder bodies.

e) Complaints and appeals

Complaints and appeals must be directed to and dealt with by an independent body. There must be confidential and effective means for workers and interested parties to register complaints.

f) Transparency

Public reporting is a crucial factor in determining the credibility of multi-stakeholder initiatives. For multi-stakeholder initiatives to become more effective

tive and credible, it is necessary to increase cooperation with local monitoring and verification structures in developing countries and to strengthen workers' education.

During the past years, there has been a growing number of Southern NGOs becoming involved in code monitoring and verification schemes like for instance GMIES in El Salvador, COVERCO in Guatemala, and EMI in Honduras. These groups have carried out independent monitoring for companies and formed regional networks.

But in order to achieve the overall aim of strengthening workers' power in the globalised economy, it is also necessary to go beyond the limits of code-related activities.

In a wider international context codes of conduct should meet the following demands:

■ INTERNATIONAL SOLIDARITY CONTEXT

Activities related to codes of conduct should be embedded in a wider perspective of international solidarity for the sake of improving labour conditions.

Workers involved in strikes, retrenchments or military repression frequently need direct solidarity support in the form of legal and financial assistance, media coverage, worker education programmes, etc. Work relating to codes of conduct cannot be successful unless the respective priorities of workers and NGOs in southern and northern countries are taken into account.

■ NATIONAL AND INTERNATIONAL REGULATION

Codes of conduct are intended to complement government regulation. Close cooperation with government institutions is necessary to avoid the danger of codes of conduct being used as a substitute for publicly enforced labour laws. The enforcement capabilities of national governments and intergovernmental institutions should be strengthened. In recent months, however, tendencies to-

wards replacing binding government regulation by voluntary codes of conduct have been strengthened. Promoters of the concept of Corporate Social Responsibility like the EU Commission and the OECD have openly opposed stronger public regulation of business behaviour. The dangers of codes of conduct not fulfilling their task of complementing government regulation are clear: "At present, much of the social force that is promoting corporate responsibility is channelling its energies and resources towards corporate self-regulation and civil regulation. Until greater public concern and civil society activism put pressure on political parties, governments and multilateral organizations to support other regulatory approaches, it is unlikely that significant developments in this area will be made." (1) The revised OECD Guidelines can be used to fulfill this function if they are made binding for member countries. The European Parliament Resolutions on codes of conduct and a new legal framework for the international operations of European-based multinational companies, adopted on 13th January 1999, and on 30th May 2002, are good examples in this direction.

■ LINK TO BROADER POLITICAL CAMPAIGNS

The labour practices of factories along the global production chain is by no means the only factor to be considered in implementing social standards for workers. This goal also depends on the broader political and social context, including financial market developments, gender discrimination in the labour market etc. If activities directly related to codes of conduct are not integrated into campaigns with wider political aims, the effectiveness of these tools will remain limited.

(1) Utting, Peter "Regulating Business via Multistakeholder Initiatives: A Preliminary Assessment", in: *Voluntary Approaches to Corporate Responsibility. Readings and a Resource Guide*, publ. By UN Non-Governmental Liaison Service / UNRISD, Geneva May 2002, p. 116



6. The New Codes Of Conduct

SOME QUESTIONS AND ANSWERS FOR TRADE UNIONISTS (REVISED JANUARY 2003)

BY NEIL KEARNEY AND DWIGHT W. JUSTICE

NEIL KEARNEY IS GENERAL SECRETARY OF THE INTERNATIONAL FEDERATION OF TEXTILE, LEATHER AND GARMENT WORKERS' UNIONS AND DWIGHT JUSTICE IS WITH THE MULTINATIONAL COMPANIES DEPARTMENT OF THE INTERNATIONAL CONFEDERATION OF FREE TRADE UNIONS

What are the "new" codes of conduct?

Beginning in the early 1990's, companies involved in the manufacture or marketing of brand-name goods produced internationally, often through outsourcing, began to formulate and adopt codes of conduct covering labour practices that were meant to apply to their subcontractors and suppliers. These unilaterally adopted company codes of international labour practice are the new codes of conduct.

Codes of conduct for business are not new – businesses have been using them for years to address various public concerns such as consumer rights, product safety, or environmental protection. Often businesses apply ethical behaviour codes to their employees. Codes of conduct for international business activity are not new either. In the 1970's, concern over the growing power of multinational companies led two international organisations to adopt codes for international business: the *ILO TRIPARTITE DECLARATION OF PRINCIPLES CONCERNING MULTINATIONAL ENTERPRISES AND SOCIAL POLICY* and the *OECD GUIDELINES FOR MULTINATIONAL ENTERPRISES*. These international instruments sought to protect the sovereignty of countries by defining the responsibilities, including the social responsibilities, of international business.

What is "new" about these codes?

They are new in four important ways:

- Although the ILO and OECD codes were voluntary, they are part of an international framework of principles agreed to by governments, employers and trade unions and recommended to companies. The new codes are being formulated and adopted by individual companies. Indeed, when formulating the earliest new codes, most companies ignored established standards in favour of creating their own.
- The purpose of the new codes does not include protection of the sovereignty of governments but is to address situations created by the failure of national governments and of the international community to adopt or enforce acceptable labour standards.
- Unlike most company policy with respect to labour practices, which is usually based on national law and practice, the new codes are meant to be applied internationally, regardless of where the work is being performed.
- The new codes are supposedly meant to protect workers whether or not they are employees of the company adopting the code and, in particular, they are meant to apply to the labour practices of the company's suppliers and subcontractors.

The new codes are sometimes termed private voluntary initiatives because they require a positive commitment by a company before they apply. This is in contrast to instruments such as the OECD Guidelines which apply to all multinational enterprises based in OECD countries whether the enterprises have accepted them or not. The guidelines reflect the consensus of the member governments of the OECD as to what constitutes responsible behaviour of international business. The concern over the negative effects of globalisation has led to a renewed interest in the OECD Guidelines, which were revised in 2000. Among the changes has been a strengthening in the follow-up mechanism and the extension of their application to OECD-based companies operating in non-OECD countries.

Are these “new” codes just another form of public relations?

The companies adopting the new codes were responding to negative publicity generated by reports of dangerous working conditions, inhumane working hours, starvation wages, brutality and the widespread use of child labour involved in the production of clothing, footwear, toys and other labour-intensive manufacturing, as well as in the production of many agricultural products. Companies operating in other sectors are now adopting similar codes.

The early new codes rarely went beyond pledging not to use child labour and to respect national law and the companies adopting them appeared to have had little intention of doing anything to make good on what essentially were promises to the public. In some cases, the companies established a “complaints procedure” and invited NGOs and trade unions to take evidence of exploitation and abuse to the company before “going public”. Many of the later codes reflect the demand that international standards be used, and increasingly, com-

COMPETITIVE ADVANTAGES MENTIONED BY CODES

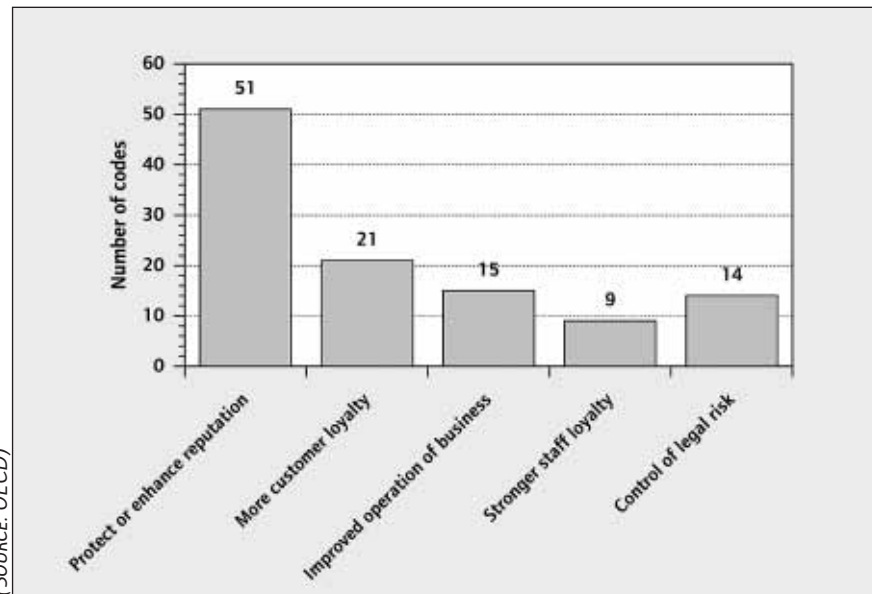

panies are being forced to consider systems of giving effect to their codes and of assuring the public that their codes are being respected. However, many of the new codes are still public relations exercises and the vast majority of these kinds of codes are not built around fundamental international labour standards. The limited research conducted to date suggests that codes have not produced major changes in labour practices.

Why should trade unions be concerned with these codes?

Whether they are policies or promises, the new codes are about labour practices and therefore cannot be ignored by trade unions. Most companies adopt codes without involving trade unions in any way and will continue to adopt codes even if trade unions dismiss or ignore codes. Indeed, the new codes have become an important part of larger debates on corporate responsibility and globalisation. The new codes are sought after by many NGOs and are attracting the interest of business and industry groups, governments, international organisations and academics. They have spawned an entire new industry of consultants and enterprises offering “social auditing” services to companies.

Because trade unions have long demanded that multinational companies assume responsibility for their international activities, it is difficult to see how they can object in principle to what is an acknowledgement of social responsibility by business. One objection to the new codes is that they can be consistent with a philosophy that seeks to privatise what ought to be the legitimate functions of government. They can be used by companies to avoid dealing with trade unions. On the other hand, the new codes can be equally consistent with the promotion of international labour standards and of a binding international framework for responsible corporate behaviour. The new codes can also be used to promote collective bargaining and to help workers form trade unions. Codes can be a means to support organising activities and to commit companies publicly to respect the right to organise and collective bargaining.



(H. KLÖPPER)

BODY CHECK AFTER WORK AT GARMENT FACTORY NEAR JAKARTA/INDONESIA

Where they are truly applied, codes may end some of the worst forms of exploitation and abuse. They also may provide opportunities for international trade union organisations to engage multinational companies. Trade union involvement with the new codes, and especially international trade union cooperation, may determine whether the new codes are used as a means to privatise the proper functions of governments and absolve governments and inter-governmental organisations of their responsibilities or whether they contribute to building a system of international social justice and industrial relations.

Should national trade union organisations negotiate codes?

The low level of trade union organisation in many of the industries and countries most concerned suggest that insisting that codes must always be negotiated with trade unions is not realistic. The international scope of the new codes makes it questionable whether it is either practicable or appropriate for national trade unions to seek to negotiate these new codes.

Because the new codes are international in scope and almost all collective bargaining takes place within national legal frameworks, the national trade union negotiating a code may be accepting responsibilities that it cannot discharge. Under these circumstances, the negotiated code may have no greater effect than a unilaterally adopted code – the only difference may be to involve national trade unions in a “complaints procedure” which only protects the company. Instead of becoming a party to a signed agreement, national trade unions can avoid complications by seeking to advise companies on appropriate code content and implementation.

Serious complications can arise when a trade union in one country seeks to negotiate working conditions for workers in another country. Where the trade union negotiating a code is from the home country of a multinational company, it may be open to charges of protecting purely national interests or protecting long-standing relationships with prominent national companies. It is unacceptable for trade unions to negotiate agreements covering workers in another country where the workers concerned are represented by their own trade union unless, of course, the foreign trade union has requested assistance and is consulted at every step. Even in this situation, it would be better to involve the appropriate Global Union Federation.

Almost all of the companies adopting the new codes are operating in sectors where most workers do not belong to trade unions and in countries where trade union rights are not respected. The exploitation and abuse of workers, which led to the need for a code in the first place, occurs because the rights of workers to join or form independent trade unions and to bargain collectively are not respected. Where workers can form independent trade unions and bargain, there may be little need for a code of conduct.

There is a big difference between speaking out on behalf of workers who are not represented and seeking to negotiate on their behalf. To say that it is possible to negotiate for unorganised workers is to say that workers can be represented without their own trade unions. The moral obligation of all trade unions toward unorganised workers is to assist them in joining or forming their own trade unions and to prevent or discourage others – whether they are governments, political parties, employers or NGOs – from claiming to speak for them.



(CIR)

Whether a trade union should negotiate an international code boils down to this: is it possible for the trade union to consult the authentic representatives of the workers who would be affected by a code? The best example of a positive answer to this question occurred during the 1980's, where trade unions in the home countries of multinational companies operating in South Africa during apartheid were able to negotiate codes on behalf of black workers in South Africa. This was possible only because the workers concerned had already established genuine, albeit illegal, trade unions and the trade unions negotiating the codes closely co-operated with these trade unions. These circumstances were exceptional.

What is the difference between a code of conduct and a framework agreement?

Some of the obstacles to negotiated codes can be overcome and some advantages gained by distinguishing between framework agreements and unilaterally-adopted company codes of labour practice. A framework agreement is an agreement negotiated between a multinational company and a Global Un-

ion Federation (GUF) concerning the international activities of that company. Global Union Federations are the international associations of trade unions grouped by industry, economic sector or profession. A number of framework agreements have been negotiated, with varying subject matters and details. Although an international code of conduct can be part of a framework agreement, and sometimes is, the main purpose of a framework agreement is to establish an ongoing relationship between the multinational company and the international trade union organisation.

Trade unions that want to engage multinational companies over their labour practices in other countries should do so in close co-operation with the appropriate GUF. Because the GUFs have affiliates throughout all regions of the world and often in both home and host countries, they are the legitimate international voice of workers in their respective industries or economic sectors. An additional advantage of working through GUFs is that trade unions will be addressing specific situations while, at the same time, strengthening the international trade union movement.

There are additional reasons to distinguish between unilaterally adopted company codes and framework agreements. One is that trade unions should not automatically dismiss codes because they are not negotiated. Trade unions can engage multinational companies over their codes without becoming party to them. Another difference is content. A framework agreement can cover a variety of subjects. For reasons explained below, a unilaterally adopted company code of labour practice should be limited to setting forth minimum standards.

What should trade unions want codes of conduct to do?

The challenge for trade unions is to make sure that the real effect of the new codes is to promote freedom of association and the right to collective bargaining and that they are not used to substitute for these two basic workers' rights. The role of trade unions is to insure that the link between exploitation and abuse of workers on the one hand, and the oppression of workers on the other,

THE LABOUR CONTENT OF THE CODES

	PERCENTAGE OF CODES MENTIONING ATTRIBUTE*
Reasonable working environment	75,7
Compliance with laws	65,5
No discrimination or harassment	60,8
Compensation	45,3
No child labor	43,2
Obligations on contractors/ suppliers	41,2
No forced labour	38,5
Provision of training	32,4
Working hours	31,8
Freedom of association	29,7
Specific mention of "human rights"	25,0
Monitoring	24,3
Right to information	13,5
ILO codes mentioned	10,1
Promotion	8,8
Reasonable advance notice	3,4
No excessive casual labour	3,4
Flexible workplace relations	0,7

(SOURCE: OECD)

is understood and reflected in codes of labour practice. Companies should not use codes as a means of avoiding trade unions. Similarly, national or local trade unions should not accept codes where they could otherwise negotiate collective agreements for the workers they represent. Codes of conduct promote good industrial relations.

How can codes promote collective bargaining?

The content of the code is crucial in two ways. First, a code of labour practice should always contain explicit provisions respecting the right of workers to either form or join trade unions and to bargain collectively. Some suppliers have used their obligation to abide by a company code as a reason not to continue a collective agreement negotiated with a local trade union and others have used codes as reasons not to recognise trade unions. Trade unions should regard ex-

PLICIT recognition of freedom of association and the right to collective bargaining as central provisions of any code of labour practice and, where these provisions are missing, demand that they be included. These rights enable workers to protect other rights, as well as their interests on a wide range of issues. The adoption in June 1998 by the ILO Conference of the ILO Declaration on Fundamental Principles and Rights at Work demonstrates the world consensus with respect to freedom of association and the right to collective bargaining, as well as all of the core ILO labour standards.

Second, codes should not contain provisions that are more appropriate for collective bargaining agreements. Unilaterally adopted company codes should only contain minimum standards that are explicitly recognised as such. The ICFTU strongly recommends that codes of labour practice be based on internationally recognised labour standards and include explicit reference to all of the fundamental labour standards of the ILO. Trade unions are invited to use the ICFTU/ITS Basic Code of Labour Practice as a benchmark in evaluating voluntary company codes of conduct.

Can international labour standards apply to companies as well as to governments?

Codes of conduct are no substitute for legislation and its effective implementation. However, company codes of conduct that promote knowledge and understanding of international labour standards indirectly promote government responsibility and may even be used to promote an international framework for business, which includes respect for workers' rights. These beneficial effects will only be possible from codes of conduct that are based on already established international standards, including ILO standards. It is not difficult to transpose the fundamental ILO conventions into obligations for international business.

Businesses seeking to define their social responsibilities almost always stress respecting the values of the community. For international business, this should mean respecting the standards of the international community. The ILO is the organisation established by the international community for the purpose of setting international labour standards.

ISSUES ADDRESSED IN APPAREL COMPANIES' CODES OF CONDUCT

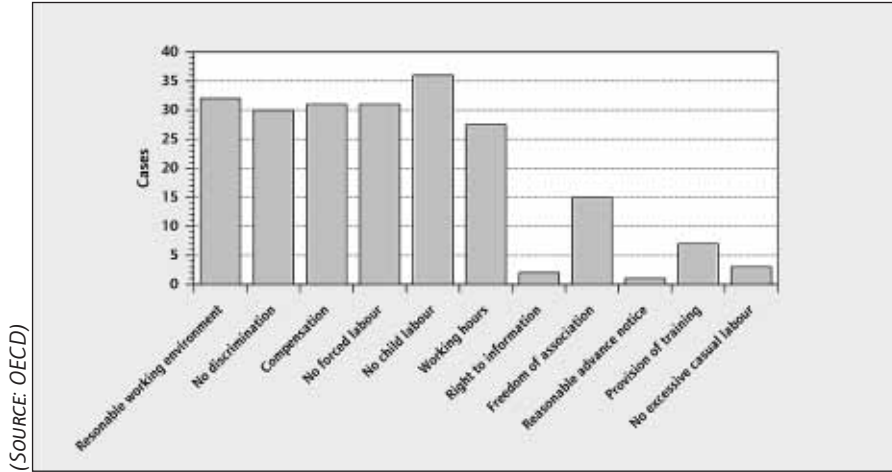

How can codes of conduct promote collective bargaining in countries where independent trade unions are banned?

The rights of workers to join or form trade unions and to bargain collectively are human rights that are only fully respected in democracies. Nevertheless, trade union experience is that, even under dictatorships, workers have been able to create or enlarge space for trade union organising and collective bargaining with some employers. This was the experience in Chile, Korea, Poland, South Africa and Turkey when these countries were dictatorships. Companies respecting human rights should therefore be alert to the possibilities of creating and enlarging the space for workers' self-organisation. In any event, companies should always avoid being party to state repression.

Some advocates of the codes of conduct that include freedom of association and the right to collective bargaining do not support boycotting countries that deny these rights. Instead, they want companies doing business in these countries to help create an environment where these rights are respected. One idea is for companies to require their suppliers to facilitate alternative or "parallel" means of workers' organisation. The supplier would not be required to estab-

lish any organisation, but would be expected to provide the workforce with the opportunity to do so in the form of elected consultative committees on health and safety, productivity and many other relevant issues.

Great care must be taken in implementing any provision to provide "parallel means" because the intervention of an employer in workers' organisations can, in itself, constitute a violation of freedom of association. Some employers would use any provision to set up organisations that they control as a means of avoiding trade unions or of using such a provision as evidence that workers do not need trade unions. For this reason, a provision concerning alternative means should only apply in a very limited set of countries. These would include those few countries such as Saudi Arabia where all trade unions are explicitly banned and those countries such as China where the state has created and controls a labour organisation monopoly. The term "parallel means" is meant to suggest that the arrangements would have a separate existence from any official government controlled system of labour organisation.

Companies doing business in countries with repressive regimes have a greater obligation to be transparent in their operations and should work with international trade union organisations so as to increase the positive and decrease the negative effects of their involvement in these countries. The purpose of encouraging alternative or parallel means is not to create substitutes for genuine trade unions or to otherwise obtain the beneficial effects of true industrial relations, but to avoid complicity in repression and to contribute toward the eventual end of repression.

Should codes reflect the special conditions in certain countries?

Some trade unions and NGOs talk about negotiating codes of labour practice reflecting the "special situation" or "unique circumstances" in their respective country or region. Settling for less than minimum international standards would defeat the whole purpose of an international code. Governments justify the repression of workers' rights and trade unions by claiming "special situa-

tions" and "unique circumstances" and many companies have found it convenient (and profitable) to accept this argument and not interfere by "imposing" their own "cultural values". One clear example of an unacceptable "cultural" exception to international standards is discrimination against women.

Although it is reasonable to expect that the content of codes will vary from company to company and between industries, the basis for these differences should centre on the relevancy of the various international standards and established best practice. For instance, in some codes it may be especially appropriate to reflect certain health and safety standards.

Should trade unions be responsible for implementing codes of conduct?

No. Companies should be responsible for implementing their own codes of conduct. Codes should be viewed as company policy and as a management tool to solve problems. Where a company has promulgated a code of conduct, it is morally bound to give it effect. Implementation is anything done to give a code effect.

FACTORY IN EXPORT-PROCESSING ZONE SAN BARTOLO IN EL SALVADOR



(H. HENSCHEN/CIR)

A company that takes its code of conduct seriously will not leave it to its public relations department or agency, but will place the overall responsibility for the implementation of the code at the highest levels and incorporate code compliance into all relevant management systems. This means assigning responsibilities throughout the company. One responsibility should be assigned to the legal department – observance of the company code should be made an enforceable, and an enforced, part of the agreements the company enters into when outsourcing. Other responsibilities belong with the personnel department – company personnel should receive training in implementing the code. Buyers must be permitted to take the cost of code compliance into account when negotiating contracts with suppliers. The labour practices of suppliers must receive the same attention as the quality of their output.

The workers covered by a code should be provided in every case with a full and understandable explanation of the code, both verbally and in written form. Workers covered by a code should also be provided a confidential and accessible means to report code violations.

In the end, the real test of implementation is whether a company does anything to correct unacceptable labour practices where they are discovered.

What does "monitoring" mean?

Where a company has adopted a code of conduct covering the labour practices of its suppliers and sub-contractors, it has acknowledged some measure of responsibility for their labour practices. The most basic obligation that follows from this responsibility is to know the actual situation in which work covered by the code is performed. This led to demands that it was not enough for companies to adopt codes but that they should also "monitor" compliance with their code. "Monitoring" came to be considered a basic part of implementing of a code.

The term "monitoring" has come into widespread use with respect to the new codes. However, the term, as it is used in connection with supplier codes, is misleading and other terms are more accurate. As it is commonly understood, the term "monitoring" implies a constant, continuous or, at least, a frequently repeated process. In most cases, this would not be possible for many compa-

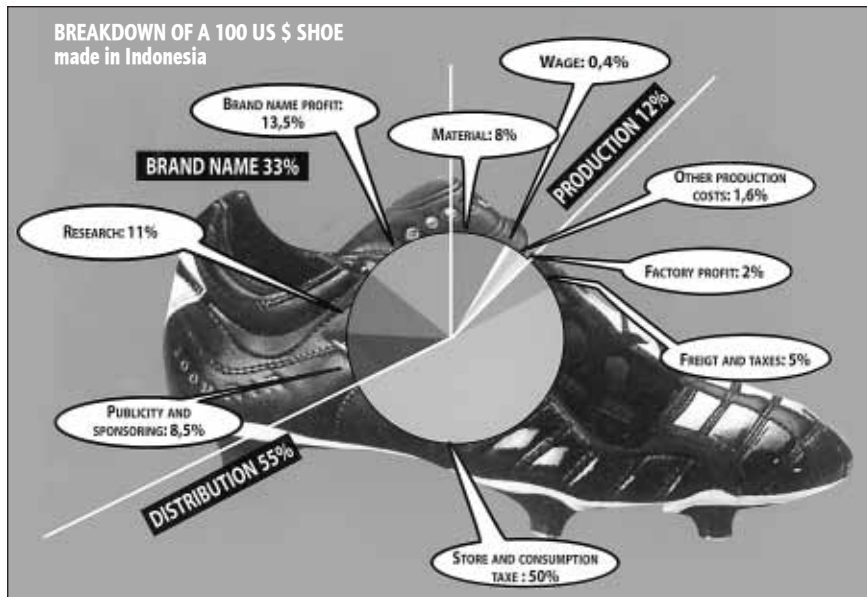

(SOURCE: MDM/OXFAM BELGIUM)

panies that adopt codes to do. The companies that adopt the new codes are likely to have many suppliers, which may use many workplaces. Often these suppliers will have subcontractors. What companies who claim to “monitor” their codes actually do is to visit the workplaces of their suppliers or to engage others to make a visit. This occurs infrequently or only once. Given the many thousands of workplaces that a sourcing company may have acknowledged responsibility for, this is not surprising.

These visits can be described as “inspections” and they can be an important part of code implementation and a sign of commitment. However, these workplace visits should not be described as “monitoring”. Sometimes inspections are part of a process that involves cross checking claims made by a supplier. Where the inspection seeks to compare different kinds of evidence with respect to code compliance, the term “auditing” could be used. An example of the auditing approach would be to compare company records concerning wages or hours with pay slips and worker interviews. Sometimes, companies who accept responsibility for the labour practices of their suppliers will chose their suppliers only after making an “assessment” of the likelihood that their labour

practices will conform to their code. Thus, the terms “assessments”, “audits” and “inspections” may be more accurate ways to describe what companies do to fulfil this basic obligation of being aware of the labour practices of their suppliers.

Trade unionists should be especially interested in reserving the use of the term “monitoring” for constant or continuous activities. Where workers are organised in a trade union at their workplace, their trade union can serve as a true “monitor” of labour practices. Indeed, the constant presence of the trade union and the protection that it affords its members, make trade unions the best and most efficient means of “monitoring”. Of course, this only applies to workplaces where the workers belong to trade unions and where the trade union is recognised and permitted to function properly.

Should trade unions be responsible for monitoring codes?

No. Companies should be responsible for monitoring or determining compliance with their own codes of conduct. Trade unions monitor workplaces where they have members in the interest of their members. Trade unions are often the organisations most aware of labour practices in their respective industries and countries. Their familiarity with unorganised workplaces arises from their role in bringing the benefits of trade unionism to unorganised workers. It is not, however, the role of trade unions to monitor or check on workplaces in the interest of ensuring that a company complies with its own policy.

Trade unions should be regularly consulted as part of the code implementation process and, of course, as part of the industrial relations process. There may be cases where trade unions enter into agreements with a company to assist this process – for example by providing interpreters or interviewers. Indeed, this may provide the trade union with access to unorganised workers. But trade unions should not enter into agreements with companies whereby they assume the responsibility for “monitoring” workplaces if they are not also legally recognised as the representatives of the workers concerned.

What about “independent monitoring”?

At present, there are no good examples of “independent monitoring” and the subject is surrounded by controversy. Indeed there is considerable confusion surrounding the term “independent monitoring” and the term “verification” is preferred by a growing number of persons most familiar with the problems involved.

The idea behind “independent monitoring” was that a code will be more credible if compliance were “monitored” by persons or organisations independent of the company that has adopted the code. Some companies have engaged commercial enterprises such as accounting firms and management consultancies to perform their “independent monitoring” or “third party verification”. Other companies have, in arrangements with their suppliers and subcontractors, designated local NGOs to be their “independent monitors”. In all of these cases, the companies, through their agreements with enterprises or NGOs, control the process.

The emerging consensus is that the term “independent monitoring” (and similar terms such as “third-party monitoring”) is more confusing than appropriate. These terms obscure the obligation of any company adopting a code of labour practice to determine whether its code is respected. Moreover, the object of “independent monitoring,” which is to provide credibility, is also obscured.

In order for so-called “independent monitoring” to be credible, it would have to be performed by qualified persons working to agreed processes. Both the qualifications of the persons and processes involved would have to be established independent of the company whose code was being monitored. In the absence of professional standards, there is no reason to accept the independence of any enterprises or NGOs engaged by a company to perform this work. Engaging a commercial enterprise or designating an NGO to “monitor” code compliance is little different from having the work done by company personnel.

Trade unionists should also be concerned where “independent monitoring” programmes are used to introduce outside organisations into the workplace on a permanent basis with the effect of discouraging or preventing workers from

joining or forming their own organisations. This is especially serious where the ‘independent monitor’ is an NGO presenting itself as an alternative to trade unions.

“Verification”, in contrast to “independent monitoring”, is a better term. It is recognised by many involved with supplier codes as a comprehensive process, involving checking on both code compliance of the supplier and the implementation systems of the company that has adopted the code. The thinking on verification is developing constantly. Many have concluded that verification should be carried out by professionals working to defined standards and trained in skills including factory inspection, accountability, health and safety and detection techniques. Whether verification is performed by commercial enterprises or non-profit agencies, the work would have to be performed following carefully defined standards and rules. It is important to be able to distinguish between the responsibility of a company to be aware of the labour practices of its suppliers and the credibility of any claims that the company may be making publicly about its code or these practices.

Who will decide whether systems of verification are credible?

Trade unions must have a role in establishing and accrediting systems of independent verification. This does not mean that only trade unions could or should verify compliance with codes. It does mean that trade unions must have a role in determining the rules or procedures, training and qualifications as well as other standards for verification and for those who would perform verification. Systems of verification must also insure that trade unions are consulted during the verification process.

Two of the most promising instances where trade unions are working with companies and NGOs to explore or establish verification systems are the Social Accountability International or SAI (formerly CEP AA) and the Ethical Trading Initiative (ETI).



INFORMAL SECTOR WORKERS IN HARARE/ZIMBABWE

SAI was established by The Council on Economic Priorities (CEP), a US-based NGO and, following a similar process as that used in ISO standard setting, it has developed an international standard for labour and human rights, known as SA 8000. The Advisory Board consists mostly of representatives from corporations and NGOs, but also includes trade union representatives.

A more experimental approach has been taken by the Ethical Trading Initiative, a partnership of NGOs, companies and trade unions, which is supported, in part, by the British government. ETI is meant to serve as a forum whereby information relating to code implementation and verification is exchanged and a means of conducting pilot studies to test various ways of monitoring and verifying codes. Several other initiatives involving companies, trade unions and NGOs have been formed in other countries. Of particular note is the Netherlands-based Fair Wear Foundation. This is also a "multi-stakeholder" initiative involving sourcing companies, trade unions, and NGOs established to implement an agreed code.

The ILO, because of its tripartite structure and the fact that it is a repository of expertise in all matters of labour practices, including labour inspection, may be the most appropriate organisation to establish benchmarks for the training of persons performing labour inspections and "social audits", for standards of verification and for the credible development of any profession of "social auditing". For this reason, and because the ILO can provide technical assistance to both social partners, the ICFTU is seeking greater involvement by the ILO with the new codes. Any involvement of the ILO in this area, however, should be firmly rooted in its commitment to labour standards, social dialogue and tripartism.

What about "social labelling"?

Trade unions should not support the certification of labour practices through the use of "social labelling" on products, at least not before accredited systems of independent verification are established and proven effective and reliable. Such product labels imply a guarantee that the item was produced free of exploitation and abuse. But, unlike product content or safety labels, the claim cannot be verified by testing the product itself. A label covering labour practices could only be credible if there was constant policing of the workplace – a condition that exists only where secure and independent trade unions are permitted to perform their proper functions and even then, only where they are supported by enforceable and enforced labour regulation in an open and democratic society.

This caution need not apply to labels developed to address some specific abuses such as child labour. In particular where producers are participating in an internationally recognised programme to eliminate child labour, then a label that indicates that the company concerned is participating in a specific programme is acceptable. Even here, care must be taken that only the participation in the programme is being certified and not the labour practices used in the product bearing the social label. This caution also does not apply to "fair-trade" labels involving trading relationships between small producers of mainly commodity products in developing countries and consumers in devel-

oped countries where these labels do not seek to “certify” labour practices. Nor does it apply to environmental labels (“eco-labelling”). In recent years some environmental and fair trade labelling schemes have begun to make claims about labour practices. These developments are cause for concern.

What is the role for NGOs in codes of conduct?

NGOs have often been the leading organisations in campaigns for codes and they have brought the issues of exploitative and abusive labour practices to the attention of the public in many countries. Trade unions should welcome these efforts and work with NGOs in this area. NGOs should work with the appropriate trade union organisations when campaigning over labour practices. NGOs have a vital role in exposing the abuse of workers throughout the world. It is important that they continue to put pressure on both governments and business to behave responsibly.

NGOs should be encouraged to base campaigns for codes of labour practice on minimum international labour standards and always to include the right of workers to organise and to bargain collectively. Demands that are more appropriate to collective bargaining should be avoided and NGOs should not participate in arrangements with companies that have the effect of substituting for independent trade unions. In any event, NGOs should not attempt to negotiate labour practices with companies or to establish regular consultative relationships with companies concerning their labour practices.

How are the new codes related to “corporate social responsibility”?

The new codes of conduct have become part of a broader debate over the social responsibilities of business. One idea of “Corporate Social Responsibility” (CSR) is being promoted as the voluntary responses by business to social

and environmental concerns. Because the new codes of conduct are voluntary initiatives, they are often linked with this notion of CSR.

There are some trade union concerns with CSR that are the same concerns that trade unionists should have with the new codes. Sometimes, businesses appear to be using CSR as a way of avoiding regulation. The important role of government is unrealistically diminished and the ability of business to resolve social and environmental problems is unrealistically exaggerated. Many embracing CSR focus entirely on management and treat the employees of an enterprise as just one group among many other “stakeholder” groups. Indeed, the responsibility of businesses to have good industrial relations and to participate in social dialogue as a social partner with workers rarely figures into the new CSR idea. In this sense, the new CSR idea can, at times, resemble the older and discredited idea of paternalism. Business should not use the interest in CSR in a way so as to avoid responsibilities by promoting the idea that enlightened management can substitute for the role of governments and trade unions in society.

Similarly, the new codes of conduct must not be allowed to be treated as an acceptable substitute for either governments or for trade unions. The demand for supplier codes came about as a result of situation caused by the failure of governments to fulfil their responsibilities and by the repression of trade unions. For the new codes to have a positive and sustainable impact, they should contribute to a culture of compliance with law and standards that strengthens the ability of governments to protect workers from abuse and exploitation. Whether the new codes have a positive and sustainable impact will also depend on whether they can create space for the workers concerned to organise trade unions to protect their own interests.

Another area where trade union concerns over CSR are the same as those that trade unionists should have with respect to the new codes concerns the role of standards. Simply put, business must not be allowed to define its own responsibilities, but should use existing, recognised and legitimate standards. With respect to the broad social responsibilities of business, two of the most important of these standards are the ILO Tripartite Declaration of Principles concerning Multinational Enterprises and Social Policy and the OECD Guidelines for Multinational Enterprises. As noted earlier, we believe that it is important for

supplier codes to reflect the principles underlying ILO standards, especially all of those standards that have been identified as fundamental rights at work. It must be stressed, however, that, while it is very appropriate for companies sourcing internationally to require their suppliers to respect these minimum human rights standards, the social responsibilities of business go well beyond respecting human rights and minimum conditions. Codes of labour practice based on minimum internationally recognised standards and meant for suppliers are an insufficient basis for companies to define their own social responsibilities with respect to work and workers.

Where do the new codes fit into the trade union strategy for globalisation?

The new codes are a phenomenon that emerged in 1990's and presents both challenges and opportunities for trade unions. As already noted, the new codes must not be allowed to become an alternative to national law or industrial relations or to absolve governments from their responsibilities. Nor should the new codes become an impediment to establishing enforceable international rules for multinational companies. More immediately, the new codes must not be used by companies to avoid trade unions and collective bargaining.

Trade unions should respond to the new codes of conduct in ways that makes them complementary to the overall objectives of the trade union movement, including the campaign for a workers' rights clause in international trade and investment agreements. The new codes should be used to promote acceptance of international labour standards and an understanding that exploitation and abuse occur because trade union rights are not respected.

The international nature of the new codes requires international trade union co-operation. The new codes may provide an opportunity to strengthen the international trade union movement by engaging multinational companies on the international level and may even lead to international social partnerships. Efforts must be made to strengthen the capacity of trade unions, particularly in developing countries, to take full advantage of the new codes.

7. Appendix

List of Selected ILO Conventions

- a) **Freedom of association and protection of the right to organise**
(No. 87, 1948)
- b) **Right to organise and collective bargaining**
(No. 98, 1949)
- c) **Forced labour**
(No. 29, 1930)
- d) **Minimum age**
(No. 138, 1973)
- e) **Discrimination in employment**
(No.100, 1951 and No. 111, 1958)
- f) **Living wage**
(No. 26, 1928 and No. 131, 1970)
- g) **Occupational safety and health**
(No. 155, 1981)
- h) **Hours of work**
(No. 1, 1919)
- i) **Establishment of employment relationship**
(not yet ILO Convention)

The ILO Conventions under a), b), c), d) and e) belong to the "core labour standards" which are the basis of the "ILO Declaration on Fundamental Principles and Rights at Work" adopted by the 86th International Labour Conference on 18 June 1998 in Geneva. This Declaration is binding for all ILO member countries.

Abbreviations

AMRC	Asia Monitor Resource Center, Hong Kong
ATTAC	International movement for the democratic control of financial markets and their institutions
BVQI	Bureau Veritas Quality International
CCC	Clean Clothes Campaign
CEP	Council on Economic Priorities
CEPAA	Council on Economic Priorities Accreditation Agency
CSR	Corporate Social Responsibility
EFTA	European Fair Trade Association
EPZ	Export-Processing Zone
ETI	Ethical Trading Initiative
FDI	Foreign Direct Investment
FLA	Fair Labor Association
FLO	Fair Trade Labelling Organisations International
FTA	Foreign Trade Association
FWF	Fair Wear Foundation
GATT	General Agreement on Tariffs and Trade
GUF	Global Union Federation (formerly International Trade Secretariat)
ICEM	International Federation of Chemical, Energy, Mine and General Workers' Union
ICFTU	International Confederation of Free Trade Unions
IFAT	International Federation for Alternative Trade
IFBWW	International Federation of Building and Wood Workers

ILO	International Labour Organisation
IMF	International Monetary Fund
ISO	International Organisation for Standardisation
ITGLWF	International Textile, Garment & Leather Workers' Federation
ITS	Intertek Testing Services
IUF	International Union of Food, Agricultural, Hotel, Restaurant, Catering, Tobacco and Allied Workers' Association
LARIC	Labour Rights in China (Asia Monitor Resource Center, China Labour Bulletin, Hong Kong Christian Industrial Committee, Hong Kong Confederation of Trade Unions)
NEWS	Network of European World Shops
NGO	Non-governmental organisation
OECD	Organisation for Economic Co-Operation and Development
SA 8000	Social Accountability 8000
SAI	Social Accountability International
SAP	Structural Adjustment Programme
SGS-ICS	International Certification Services
TIE	Transnational Information Exchange Asia
TNC	Transnational Corporation
UNCTAD	United Nations Conference on Trade and Development
UNDP	United Nations Development Programme
UNI	Union Network International
WRAP	Worldwide Responsible Apparel Production
WRC	Worker Rights Consortium
WTO	World Trade Organisation

Glossary

In recent years, the following terminology and definitions have been developed in the international debate on codes of conduct:

■ IMPLEMENTATION

→ This means anything done by a company to give effect to a code.

■ MONITORING

→ This means anything done by a company to check if the provisions of a code are being observed. Monitoring as an ongoing process is basic to implementing. Often this is also called "internal monitoring".

■ VERIFICATION

→ Also called "independent verification". This means institutionalised checking on implementation and monitoring systems of a company by an independent body.

At the beginning of the international code of conduct debate, "independent verification" was often also called "independent monitoring". The independent verification institution can appoint commercial audit companies and/or non-profit agencies to perform audits following carefully defined standards and rules (also called 'social auditing').

■ EXTERNAL MONITORING

→ This means monitoring by third parties on a spot-check basis, and not on a regular institutionalised basis.

■ SOCIAL AUDITING

→ See under "Verification".

Bibliography

Ascoly, N. and Zeldenrust, I.: "Discussing Key Elements of Monitoring and Verification", SOMO Amsterdam 2001

Ascoly, N., Oldenziel, J. and Zeldenrust, I.: "Overview of Recent Developments on Monitoring and Verification in the Garment and Sportswear Industry in Europe", SOMO Amsterdam 2001, available online (www.somo.nl)

David, Natacha: "Worlds apart – Women in the Global Economy", ed. ICFTU, Brussels 1996

ICFTU: "Globalising Social Justice, Trade Unionism in the 21st Century", Brussels 2000

ILO: "Labour practices in the footwear, leather, textiles and clothing industries", Report for discussion at the Tripartite Meeting on Labour Practices in the Footwear, Leather, Textiles and Clothing Industries, Geneva 2000

ILO: "Labor and social issues relating to export processing zones", Report for discussion at the Tripartite Meeting of Export Processing Zones – Operating Countries, Geneva 1998

ILO: "Trade unions and the informal sector: Towards a comprehensive strategy", International Symposium on Trade Unions and the Informal Sector, Geneva 18–22 October 1999

ILO: "Decent work and the informal economy", Report VI, International Labour Conference, 90th Session, June 2002, Geneva

ILO Governing Body: "Overview of global developments and Office activities concerning the codes of conduct, social labelling and other private sector initiatives addressing labour issues", Geneva November 1998

ILO Governing Body: "Further examination of questions concerning private initiatives, including codes of conduct", Geneva March 1999

ILO/ACTRAV: "Corporate Codes of Conduct and Labour Standards", by Jill Murray, www.ilo.org/actrav 25.10.02

ILO/MCC: "Self-regulation in the workplace: Codes of conduct, social labeling and socially responsible investment", by Michael Urminsky (ed.), MCC Working Paper Nr. 1, Geneva 2001

Köpke, R. and Röhr, W.: "Documentation: Project Presentation and International Seminar of the Research Project 'Codes of Conduct and Monitoring'", Hamburg University of Economics and Politics / Hans Böckler Foundation, Hamburg 2002

LARIC: "No Illusions: Against the Global Cosmetic SA8000", Hong Kong Labor Rights in China, Hong Kong 1999

Maquila Solidarity Network: "Memo: Codes Update", 2–4 issues/year (No. 1: April 1999), available online (www.maquilasolidarity.org)

Marthoz, Jean-Paul / Szymanski, Marcela: "Behind the wire. Union Repression in the Export-Processing Zones", ed. ICFTU, Brussels 1996

OECD: "The OECD Guidelines for Multinational Enterprises", Revision 2000, Paris 2000

OECD Working Party of the Trade Committee: "Codes of Corporate Conduct: An Inventory", 29 April 1999

OECD Working Party of the Trade Committee: "Codes of Corporate Conduct – An Expanded Review of their Contents", 7 June 2000

O'Rourke, Dara: "Monitoring the Monitors: A Critique of Pricewaterhouse-Coopers (PwC) Labor Monitoring", Cambridge, MA 2000, available online (web.mit.edu/dorourke/www/index.html)

Piepel, Klaus: "Social Labels and Codes of Conduct. A Position Paper", eds. Misereor/Brot für die Welt, Fair Trade Policy No. 2, Aachen/Germany 2000

Scherrer, Christoph / Greven, Thomas: "Global Rules for Trade. Codes of Conduct, Social Labeling, Workers' Rights Clauses", Münster 2001

UNCTAD: "World Investment Report 2002", Geneva 1998

UNDP: "Human Development Report 2002", New York 2000

UN Non-Governmental Liaison Service / UNRISD: "Voluntary Approaches to Corporate Responsibility. Readings and a Resource Guide", NGLS Development Dossier, Geneva 2002

UNO: "1999 World Survey on the Role of Women in Development. Globalisation, Gender and Work", New York 1999

Utting, Peter: "Business Responsibility for Sustainable Development", OPG 2, UNRISD Geneva 2000

Verweij, Myrthe: "Using the OECD Guidelines for Multinational Enterprises. A critical starterkit for NGOs", ed. Friends of the Earth Netherlands, Amsterdam 2002

Wick, Ingeborg: "The Exception and the Rule – The Relationship between Formal and Informal Employment", in: Shadow Economy and Trade Unions, DGB Bildungswerk Materialien Nr. 71, Düsseldorf 2000

Women Working Worldwide: "Women Workers and Codes of Conduct. Report of Preliminary Research and Consultation Exercise", Manchester 1998

Women Working Worldwide: "Women Workers and Codes of Conduct. Asia Workshop Report", Manchester 1998

Women Working Worldwide: "Women Workers and Codes of Conduct. Central America Workshop Report", Manchester 1999

Women Working Worldwide: "Organising along International Subcontracting Chains in the Garment Industry", September 2000 Workshop Report, Manchester 2001

Zeldenrust, Ineke / Ascoly, Nina: "Codes of Conduct for Transnational Corporations. An Overview", eds. IRENE, Tilburg/Netherlands 1998

Contact addresses

FRIEDRICH EBERT STIFTUNG

Godesberger Allee 149
D 53175 Bonn
Federal Republic of Germany
Telephone +49-(0)228-883-517
Telefax +49-(0)228-883-623
e-mail schweise@fes.de
website www.fes.de

SÜDWIND INSTITUT FÜR ÖKONOMIE UND ÖKUMENE

Lindenstr. 58-60
D 53721 Siegburg
Federal Republic of Germany
Telephone +49-(0)2241-259530
Telefax +49-(0)2241-51308
e-mail wick@suedwind-institut.de
website www.suedwind-institut.de

INTERNATIONAL TEXTILE, GARMENT & LEATHER WORKERS' FEDERATION (ITGLWF)

8, rue Joseph Stevens
B 1000 Brussels
Belgium
Telephone +32-2-5122606
Telefax +32-2-5110904
e-mail office@itglwf.org
website www.itglwf.org

INTERNATIONAL CONFEDERATION OF FREE TRADE UNIONS (ICFTU)

Boulevard du Roi Albert II, Bte 1
B 1210 Brussels
Telephone +32-2-2240211
Telefax +32-2-2015815
e-mail multinationals@icftu.org
website www.icftu.org

INTERNATIONAL LABOUR ORGANISATION (ILO)

4, route des Morillons
CH 1211 Geneva 22
Switzerland
Telephone +41-22-7997940
Telefax +41-22-7998577
e-mail webinfo@ilo.org
website www.ilo.org

CLEAN CLOTHES CAMPAIGN (CCC)

European coordination office
P.O. Box 11584
NL 1001 GN Amsterdam
The Netherlands
Telephone +31-20-4122785
Telefax +31-20-4122786
e-mail ccc@xs4all.nl
website www.cleanclothes.org

FAIR WEAR FOUNDATION

P.O. Box 69265
NL 1060 CH Amsterdam
The Netherlands
Telephone +31-20-4084255
Telefax +31-20-4084254
e-mail info@fairwear.nl
website www.fairwear.nl

SOCIAL ACCOUNTABILITY INTERNATIONAL (SAI)

220 East 23rd Street, Suite 605
New York, NY 10010
USA
Telephone +1-212-684-1414 x204
Telefax +1-212-684-1515
e-mail lbernstein@sa-intl.org
website www.sa-intl.org

ETHICAL TRADING INITIATIVE (ETI)

2nd Floor, Cromwell House
14 Fulwood Place
London WC1V 6HZ
Telephone +44-20-7404-1463
Telefax +44-20-7831-7852
167. S. 96: 1505 22nd Street, NW
Washington, DC 20037
e-mail eti@eti.org.uk
website www.ethicaltrade.org

FAIR LABOR ASSOCIATION (FLA)

1420 K St., NW
Washington, DC 20005
USA
Telephone +1-202-8981000
Telefax +1-202-8989050
e-mail heerden@fairlabor.org
website www.fairlabor.org

WORKER RIGHTS CONSORTIUM (WRC)

5 Thomas Circle NW, Fifth Floor
Washington, DC 2005
USA
Telephone +1-202-387-4884
Telefax +1-202-387-3292
e-mail wrc@workersrights.org
website www.workersrights.org

WORLDWIDE RESPONSIBLE APPAREL PRODUCTION (WRAP)

Suite 1016, 200 North Glebe Road
Arlington, VA 22203
USA
Telephone +1-703-2430970
Telefax +1-703-2438247
e-mail info@wrapapparel.org
website www.wrapapparel.org

THE GLOBAL COMPACT OFFICE

United Nations
Room DC1-1170
New York, NY 10017
USA
Telephone +1-212-917 367 3483
e-mail globalcompact@un.org
Website www.unglobalcompact.org

ORGANISATION FOR ECONOMIC CO-OPERATION AND DEVELOPMENT (OECD)

Head of Publications Service
2 rue André Pascal
F 75775 Paris Cedex 16
France
Telephone +33-1-45248200
Telefax +33-1-45248176
website www.oecd.org

EUROPEAN PARLIAMENT

Richard Howitt MEP
Rue Wiertz
B 1047 Brussels
Belgium
Telephone +32-2-2845477
Telefax +32-2-2849477
e-mail rhowitt@europarl.eu.int

FAIRTRADE LABELLING ORGANISATIONS INTERNATIONAL (FLO)

Kaiser-Friedrich-Str. 13
D 53113 Bonn
Germany
Telephone +49-228-949230
Telefax +49-228-2421713
e-mail coordination@fairtrade.net
website www.fairtrade.net

EUROPEAN FAIR TRADE ASSOCIATION (EFTA)

Boschstraat 45
NL 6211 JB Maastricht
The Netherlands
Telephone +31-43-3256917
Telefax +31-43-3258433
e-mail efta@antenna.nl

INTERNATIONAL FEDERATION OF ALTERNATIVE TRADE (IFAT)

30 Murdock Road
Bicester
Oxon OX26 4RF
United Kingdom
Telephone +44-01869249819
Telefax +44-01869246381
e-mail info@ifat.org.uk
website www.ifat.org

NETWORK OF EUROPEAN WORLD SHOPS (NEWS)

139, Rue Haute / Hoogestraat
B 1000 Brussels
Telephone +32-2-213-1233
Telefax +32-2-213-1251
e-mail info@worldshops.org
website www.worldshops.org

SÜDWIND INSTITUT FÜR ÖKONOMIE UND ÖKUMENE

The SÜDWIND Institut für Ökonomie und Ökumene ("South Wind Institute of Economics and Ecumenism") is a church-oriented third world research center which was founded in 1991 in Cologne/Germany. SÜDWIND analyses different sectors of the world economy from the perspective of the poor and develops options for change. It closely cooperates with similar organisations, trade unions, womens' groups etc. in countries of the South and the North.

Current research topics are:

- Cancellation of third world debts
- Ethical investment
- Social standards in the world-wide garment industry
- International second-hand garment trade
- Informal work/economy



FRIEDRICH-EBERT-STIFTUNG

The Friedrich-Ebert-Stiftung is a non-governmental, non-profit organisation committed to the ideas and basic values of social democracy and the labour movement. It bears the name of Germany's first democratically elected president, Friedrich Ebert, and continues to pursue his legacy of building freedom, democracy and social justice, both in Germany and internationally. International cooperation and dialogue is mainly organised through an extensive network of more than 100 field offices around the world



Workers' tool or PR ploy?

A guide to codes of international labour practice

By Ingeborg Wick

Since the early 1990s, codes of conduct for multinational corporations have been proliferating. It is increasingly difficult to distinguish between the different code models. Workers all over the world are confronted with new instruments which claim to improve their labour conditions.

What are the pros and cons of codes of conduct? In which way can they be useful instruments for trade unions? How can trade unions and non-governmental organisations cooperate with regard to codes of conduct? What are the main features of current code examples and the results of a comparison between them ?

This brochure concentrates on profiles of the Ethical Trading Initiative, Fair Labor Association, Social Accountability International, Worker Rights Consortium, Clean Clothes Campaign and a comparison between them. Next to an outline of the socio-economic context and other trade-related initiatives, this publication also contains an analysis of the trade union perspectives on codes of conduct by the International Confederation of Free Trade Unions and the International Textile, Garment & Leather Workers' Federation.

